

Instructions for assembly and operation

**Bearing Distance and Temperature Monitoring System
BTMS/ BDMS /BDTMS / BDTCMS**



© Dr. E. Horn GmbH & Co.KG
Sensors-Monitoring-Systems
Im Vogelsang 1
D-71101 Schoenaich

Tel.: +49 (0) 7031 63 02-0
Fax: +49 (0) 7031 63 02-99

E-Mail: info@dr-horn.org
Internet: www.dr-horn.org

Release:

Created by:

Kothes!

Technische Kommunikation GmbH & Co. KG

www.kothes.de



1	General	7
1.1	Information on this Manual	7
1.2	Explanation of symbols	8
1.3	Limitation of liability.....	9
1.4	Copyright.....	9
1.5	Spare parts	10
1.6	Warranty terms	10
1.7	Customer Service	10
2	Safety	11
2.1	Customer's responsibility.....	11
2.2	Personnel requirements.....	12
2.2.1	Qualifications.....	12
2.2.2	Unauthorized persons	13
2.3	Intended use	13
2.4	Personal protective equipment	14
2.5	Specific dangers	15
2.6	Conduct in a dangerous situation and in case of accidents.....	19
2.7	Environmental protection	20
3	Technical data	21
3.1	Indication unit.....	21
3.1.1	Type MDA312.....	21
3.1.2	Type MDA312... in field housing GHG02631	22
3.2	Line Converter box	23
3.2.1	Type GHG02611-4	23
3.2.2	Type GHG02611-5	24
3.3	Terminal box GHG02621-3.....	24
3.4	Distance sensor IW000184.....	25
3.5	Water-in-oil sensor FRG00032-6_AW	26
3.6	Main bearing temperature sensor TGL00921/TGL00921-1.....	27
3.7	Emissions.....	27
4	Structure and function	28
4.1	Overview	28
4.2	Brief description	29
4.3	Description of assemblies.....	30
4.3.1	Sensors	30
4.3.1.1	Distance sensor	30



Table of contents

	4.3.1.2	Water-in-oil sensor	31
	4.3.1.3	Temperature sensor for main bearing (optionally available)	32
	4.3.1.4	Temperature sensor for splash oil (optionally available)	32
	4.3.1.5	33	
	4.3.2	Sensor brackets	34
	4.3.2.1	Tube type sensor brackets	34
	4.3.2.2	Profile type sensor brackets	35
	4.3.3	Terminal box	37
	4.3.4	Line Converter box	38
	4.3.5	Indication unit	39
4.4		Connections	41
4.5		Work and danger zones	43
4.6		Operating elements	44
5		Transport, packing and storage	45
5.1		Safety notes for transport	45
5.2		Transport inspection	46
5.3		Transport	46
5.4		Packing	47
5.5		Storage	48
6		Installation, fixing and commissioning	49
6.1		Safety	49
6.2		Preparations	51
	6.2.1	Preparing the installation into new engines under assembly	51
	6.2.2	Preparing the installation as a retrofit	52
6.3		Installation	53
	6.3.1	Preface	53
	6.3.2	Mounting the sensor brackets	55
	6.3.3	Implementation of alignment pins	60
	6.3.4	Mounting and adjusting the sensors	61
	6.3.5	Placing and fixing of cables inside the engine	68
	6.3.5.1	Placing and fixing of cables inside new engines under construction	69
	6.3.5.2	Placing and fixing of cables for retrofit installation	72
	6.3.6	Mounting BLG00402 and BLG00403	73
	6.3.7	Mounting Terminal and Line Converter box without BLG0040	76



6.3.8	Connecting the Terminal box	76
6.3.8.1	Connecting sensors	78
6.3.8.2	Connecting the bus cable	79
6.3.9	Connecting the Line Converter box	80
6.3.9.1	Connecting the bus cables from the Terminal boxes	82
6.3.9.2	Connecting to the ship's/plant's power supply	82
6.3.9.3	Connecting the bus cable of the Indication unit	84
6.3.10	Mounting the Indication unit	84
6.3.11	Connecting the Indication unit	85
6.3.11.1	Connecting the power supply	87
6.3.11.2	Connecting the bus cable from the Line Converter box	88
6.3.11.3	Connecting the engine alarm and engine safety system	89
6.3.11.4	Other connectors	90
6.4	Checks	91
6.5	Commissioning	93
7	Operation	94
7.1	Safety	94
7.2	Operating the Indication unit	94
7.3	Testing a water-in-oil-sensor	97
8	Maintenance	98
8.1	Safety	98
8.2	Maintenance schedule	100
8.3	Maintenance tasks	101
8.3.1	Changing distance sensors	101
8.3.2	Inspecting a main bearing after production test run	104
8.4	Screw tightening torques	105
8.5	Measures after maintenance	105
9	Troubleshooting	106
9.1	Safety	106
9.2	Troubleshooting chart	109
9.3	Troubleshooting	110
9.3.1	Checking the electrical connection of the Indication unit	110
9.3.2	Checking the bus cables of the Indication unit and power supply	110
9.3.3	Checking distance sensors	112



Table of contents

9.3.4	Checking main bearing temperature sensor	113
9.3.5	Checking water-in-oil sensor	114
9.3.6	Checking function of the Terminal box	115
9.4	Startup after eliminating fault	115
10	Appendix	116
10.1	Installation schemata for the distance sensors	116
10.2	Connection table Sensor-Terminal box	118
10.3	System installation schemata	119
11	Index	121



1 General

1.1 Information on this Manual

This Manual provides important information on how to work with the device safely and efficiently.

The Manual is part of the device, must always be kept in the device's direct proximity and should be available for the personnel at any time. All personnel working with the device is obliged to have this Manual read and understood before starting any work. Strict compliance with all specified safety notes and instructions is a basic requirement for safety at work.

Moreover, the accident prevention guidelines and general safety regulations applicable at the place of use of the device must also be complied with.

For better representation of circumstances the illustrations used are not necessarily to scale and may vary from the actual design of the device.

The enclosed manuals for the installed components apply alongside this Manual.

The information in this manual is valid for all systems. The chapters Commissioning, Operation and Troubleshooting have slightly changed in systems ordered after 1. January 2009. For this systems please see document "User Interface Manual" DK002208.



General

1.2 Explanation of symbols

Warnings

Warnings are identified by symbols. These warnings are introduced by signal words, which express the severity of a danger. Adhere to these warnings and act cautiously in order to avoid accidents, personal injuries and damage to property.



DANGER!

... indicates an imminently hazardous situation which, if not avoided, will result in death or serious injury.



WARNING!

... indicates a potentially hazardous situation which, if not avoided, could result in death or serious injury.



CAUTION!

... indicates a potentially hazardous situation which, if not avoided, may result in minor or moderate injury.



CAUTION!

... indicates a potentially hazardous situation which, if not avoided, may result in property damage.

Hints and recommendations



NOTE!

... emphasizes useful hints and recommendations as well as information for efficient and trouble-free operation.

Special safety notes

The following symbols are used in connection with the safety notes to highlight particular dangers:



... highlights hazards caused by electric current. There is a danger of serious injury or death if the safety notes are not complied with.



1.3 Limitation of liability

All information and notes in this Manual were compiled under due consideration of valid standards and regulations, the present status of technology and our years of knowledge and experience.

The manufacturer can not be made liable for damage resulting from:

- disregarding this Manual
- unintended use
- employment of untrained personnel
- unauthorized conversions
- technical modifications
- use of unapproved spare parts

In case of customised versions the actual scope of delivery can vary from the explanations and representations in this Manual, because of the utilization of additional options or due to latest technical changes.

Apart from this, the obligations agreed upon in the delivery contract, the general terms and conditions and the delivery conditions of the manufacturer and the legal regulations valid at the time of contract do apply.

We reserve the right to make technical modifications without further notice in order to improve usability.

1.4 Copyright

This Manual is protected by copyright law and exclusively to be used for internal purposes.

Passing this Manual on to third parties, duplication of any kind – even in form of excerpts – as well as the use and/or disclosure of the contents without the written consent of the manufacturer is not permitted, except for internal purposes.

Violations oblige to compensation. The right for further claims remains reserved.



General

1.5 Spare parts



WARNING!

Safety hazard caused by wrong spare parts!

Wrong or faulty spare parts can adversely affect safety and cause damage, malfunctions or total failure.

Therefore:

- Use only genuine spare parts from the manufacturer.

Purchase spare parts from authorised dealers or directly from the manufacturer. For address, see page 2.

The spare-parts list can be found in the appendix.

1.6 Warranty terms

The warranty terms are provided in the manufacturer's terms and conditions.

1.7 Customer Service

Our Customer Service is always available for technical information.

Notes on the responsible contact partner are on call by phone, fax, e-mail or via internet, see address of manufacturer on page 2.

Apart from that, our members of staff are permanently interested in receiving new information and experience resulting from the use of our products and which could be of great value for future improvements.



2 Safety

This paragraph provides an overview of all important safety aspects for optimal protection of personnel as well as safe and trouble-free operation.

Disregarding this Manual and safety regulations specified therein may result in considerable danger.

2.1 Customer's responsibility

The device is implemented commercially. Thus the owner of the device is subject to legal industrial safety obligations.

In addition to the safety instructions in this Manual, the safety, accident prevention guidelines and environmental protection regulations, applicable at the site of implementation must be complied with. In particular:

- Owner must inform himself of applicable industrial safety regulations and determine additional hazards that arise due to the specific working conditions prevailing at the site where the device is implemented, in a risk analysis. The risk assessment must be implemented in the form of work instructions for device operation.
- Owner must check throughout the entire implementation period of the device, whether the work instructions that owner has created satisfy current legislation, and must adapt the instructions if necessary.
- Owner must clearly regulate and specify the responsibilities for installation, operation, maintenance, and cleaning.
- Owner must ensure that all employees who deal with the device have read and understood this Manual.
In addition, owner must train personnel at regular intervals and inform personnel of the hazards.
- Owner must provide personnel with the required protective equipment.

In addition, owner is responsible to ensure that the device is always in a technically perfect condition, and therefore the following applies:

- Owner must ensure that the maintenance intervals described in these operating instructions are complied with.
- Owner must have all safety devices inspected regularly for function and completeness.



Safety

2.2 Personnel requirements

2.2.1 Qualifications

**WARNING!****Danger of injury if insufficiently qualified!**

Improper operation can lead to serious personal injuries or property damage.

Therefore:

- Have all activities performed only by qualified personnel.

The following qualifications are specified for different areas of activity listed in the Manual.

■ **An instructed person**

has been instructed by the customer in an orientation session on the assigned tasks and possible dangers in case of improper behavior.

■ **Qualified personnel**

based on their professional training, know-how and experience as well as knowledge of the applicable standards and regulations is able to perform assigned work activities and to detect and avoid possible dangers on their own.

■ **A professional electrician**

based on his/her professional training, know-how and experience as well as knowledge of the applicable standards and regulations is able to perform work on electrical systems and to detect and avoid possible dangers on his/her own.

The professional electrician has been trained for the special location where he/she works and knows the relevant standards and regulations.

Only persons who are expected to perform their tasks reliably are permitted as personnel. Persons whose reaction capability is impaired, e.g. through drugs, alcohol or medication are not permitted.

- When selecting the personnel, the stipulations regarding age and occupation applying at the location must be observed.



2.2.2 Unauthorized persons

**WARNING!****Danger for unauthorized persons!**

Unauthorized persons not meeting the requirements outlined here are not aware of the dangers in the work area.

Therefore:

- Keep unauthorized persons away from the work area.
- If in doubt, address the persons and direct them to leave the work area.
- Interrupt work activities as long as unauthorized persons are present in the work area.

2.3 Intended use

The device has been designed and constructed exclusively for the purpose mentioned here.

The device must only be used for the monitoring of bearing distances and temperatures of 2-stroke diesel engines with 4-14 cylinders.

Only the optionally available components described in these instructions may additionally be installed.

**WARNING!****Danger in case of unintended use!**

Every use of the appliance above and/or different from the intended use may lead to dangerous situations.

Therefore:

- Use the appliance only in compliance with the regulations.
- Follow all instructions contained in these installation instructions.

Claims of any kind concerning damages caused by unintended use are excluded.

The operator is liable for all damages through unintended use.



Safety

2.4 Personal protective equipment

Wearing of personal protective equipment is required when working to minimize the health hazards.

- Always wear the protective equipment that is necessary for the respective task when working.
- Follow the instructions on personal protective equipment that are posted in the work area.

Wear generally

Generally wear for all kind of work:



Protective clothing

are tight fitting working clothes with low tear resistance, with light sleeves and without any sticking out parts. These clothes are mainly a protection against being caught by moving machine parts. Do not wear rings, chains, necklaces, and other jewellery.



Safety boots

to protect against heavy parts falling down or slipping on slippery ground.

Personal protective equipment for special tasks

When performing special tasks it is necessary to wear personal protective equipment. This personal protective equipment will be separately specified in the chapters of this Manual. This special protective equipment is explained below.



Hard hat

to protect against parts and materials falling down and flying around.



Protective gloves

to protect the hand against friction, graze, punctures or deep cuts as well as contact with hot surfaces.



Safety belt

to protect against falling, if there is a higher risk of falling.

This risk is imminent if certain differences in height are exceeded and the working area is not protected by a banister.

Wear the safety belt so that the safety rope is attached to the belt and to a fixed anchoring point. If necessary use a fall damper.

Safety belts must be used only by persons who have been specially trained for this purpose.

**Ear defenders**

to protect against hearing damage.

2.5 Specific dangers

The following section lists the residual risks that have been determined by the risk assessment.

- Heed the safety instructions listed here, and the warnings in subsequent chapters of this Manual, to reduce health hazards and to avoid dangerous situations.

Electric current

**DANGER!****Danger to life caused by electric current!**

Touching conductive parts causes a direct danger to life. Damage to insulations or individual components can cause danger to life.

Therefore:

- In the event of damage to insulation switch off the power supply immediately and have the defective parts repaired.
- Work on the electric system must be carried out only by skilled electricians.
- De-energize the machine for all work on the electrical system.
- Before maintenance, cleaning or repair work, switch off the power supply and secure it against being switched on again.
- Do not bridge fuses or make them ineffective. When changing fuses make sure you use the correct amperage.
- Keep moisture away from conductive parts. This can cause short circuit.

Engine

**WARNING!****Danger to life caused by engine in progress!**

Starting the engine while working on or inside of it may cause very serious injury or even lead to death.

Therefore:

- Switch off the engine before performing any work and make sure that it cannot be switched on accidentally.



Safety

Pneumatics

**WARNING!****Danger of injury caused by pneumatic energies!**

Pneumatic energies can cause severe injuries. Pneumatically driven parts may start to move unexpectedly.

In the event of damage to individual components, air can escape under high pressure and e.g. damage the eyes.

Therefore:

- Have work on the pneumatic system carried out only by trained expert personnel.
- Before starting work on the pneumatic system, shut down the system and relieve the pressure. Be careful of pressure accumulators. Relieve also the pressure in accumulators.
- Do not change pressures to values higher than the specified maximum values.

Oil pressure

**WARNING!****Danger of injury caused by oil under pressure!**

In case of defective lines or machine parts oil may escape under pressure. This can cause severe injuries.

Therefore:

- Do not open pipelines under pressure.
- Depressurize pipelines before starting any work.
- Have defective parts repaired.

Vibrations

**WARNING!****Health hazard caused by strong vibrations!**

Exposure to strong vibrations over a long time can cause considerable damage to health.

The source of vibration is to be isolated from the environment by means of vibration dampers.

Therefore:

- Do not adversely affect the function of the vibration dampers.
- Do not remain inside the danger zone during operation.

**Highly flammable materials****WARNING!****Fire hazard by highly flammable materials!**

Highly flammable materials, liquids or gases may catch fire causing serious and even fatal injuries.

Therefore:

- Do not smoke within the danger zone and the immediate vicinity. Avoid using open flames or ignition sources.
- Keep a fire extinguisher ready.
- Report suspicious materials, liquids or gases immediately to the person in charge.
- Suspend any work activities in case of fire. Leave the danger zone until the all clear signal is given.

Hot operating materials**WARNING!****Danger of burning by hot operating materials!**

Operating materials may become very hot during operation and cause burns when contacted.

Therefore:

- Before handling operating materials check their temperature. Allow to cool down, if necessary.

Adhesive**WARNING!****Danger of poisoning through solvents!**

Adhesives contain toxic solvents. The contact with adhesives may cause serious injuries such as poisoning, allergies or skin irritations.

Therefore:

- Obey safety data sheets of manufacturer!
- Never take in or swallow adhesives. When taken unintentionally, visit a physician immediately. Show package to physician.
- Avoid skin contact. Wear protective gloves. In case of skin contact, rinse immediately under running water.
- Do not eat or drink while working.
- Wash hands before breaks and after work completion.



Safety

Noise



WARNING!
Hearing damage caused by noise!

The noise level in the working area can cause severe hearing damage.

Therefore:

- Wear ear defenders when prescribed.
- Stay inside the danger zone only as long as absolutely necessary.

Engine oil and fuel



WARNING!
Fire hazard due to engine oil and fuel!

Steam from oil and fuel may inflame in case of contact to ignition source.

Therefore:

- No open fire when working on the engine.
- Do not smoke.
- Remove any residues of oil and fuel from engine and floor.

Hot surfaces



CAUTION!
CAUTION!
Danger of burning on hot surfaces!

Contact with hot components can cause severe burns.

Therefore:

- Always wear protective clothes and protective gloves when working on hot components.
- Before starting work make sure that all components have cooled down to ambient temperature.

**Sharp corners and pointed edges****CAUTION!****Danger of injuring on corners and edges!**

Sharp corners and pointed edges can cause graze and cuts in the skin.

Therefore:

- Take care when working near sharp corners and pointed edges.
- Wear protective gloves, if in doubt.

Dirt and objects laying around**CAUTION!****Slipping and tripping hazard!**

Dirt and objects laying around are sources for slipping and tripping over and can lead to severe injury.

Therefore:

- Keep the working area clean and tidy.
- Remove objects that are no longer needed.
- Mark sources of tripping over with yellow-black marking tape.

2.6 Conduct in a dangerous situation and in case of accidents

Preventive action

- Always be prepared for accidents or fire!
- Keep first aid equipment (first aid kit, covers, etc.) and fire extinguisher close at hand.
- Instruct your personnel about accident reporting, first aid and rescuing facilities.
- Keep escape routes and access ways clear for rescue vehicles.

In case of emergencies

- Operate the emergency stop immediately.
- Initiate first aid measures.
- Rescue persons from the danger zone.
- Inform responsible persons at the place of action.
- Call for rescue service.
- Keep access ways clear for rescue vehicles.



Safety

2.7 Environmental protection



CAUTION!
Environmental hazard caused by incorrect handling!

Incorrect handling of environmentally hazardous substances, especially incorrect waste disposal, can cause considerable damage to the environment.

Therefore:

- Always comply with the following information.
- If environmentally hazardous substances are accidentally released into the environment, you must immediately apply appropriate countermeasures. If in doubt, consult the responsible municipal authority to inform about the damage.

The following environmentally hazardous substances are used:

Lubricants

Lubricants like greases and oils contain toxic substances. These must not be released into the environment. They must be disposed of by a special waste disposal company.



3 Technical data

3.1 Indication unit

3.1.1 Type MDA312...

Specification	Value	Unit
Weight	2,100	kg
Length	230	mm
Width	164	mm
Height	82	mm

Electrical connection values

Specification	Value	Unit
Supply voltage	24	V DC
Supply current, maximal	1	A
Power consumption, maximal	25	W
External fuse** (delayed action)	2	A
Protection	IP66	front
	IP20	back

Relay data

Specification	Value	Unit
Load voltage	60	V DC
Load current, maximal	250	mA SCP



Technical data

3.1.2 Type MDA312... in field housing GHG02631

Specification	Value	Unit
Weight	6,250	kg
Length	300	mm
Width	268	mm
Height	180	mm

Electrical connection values

Specification	Value	Unit
Supply voltage	24	V DC
Supply current, maximal	1	A
Power consumption, maximal	25	W
External fuse** (delayed action)	2	A
Protection	IP66	

Relay data

Specification	Value	Unit
Load voltage	60	V DC
Load current, maximal	250	mA SCP



3.2 Line Converter box

3.2.1 Type GHG02611-4

Specification	Value	Unit
Weight	8,200–9,200	kg*
Length	400	mm
Width	268	mm
Height	180	mm

Electrical connection values

Specification	Value	Unit
Supply voltage	24	V DC
Supply current, maximal	6	A
Power consumption, maximal	125	W
External fuse** (delayed action)	10	A
Protection	IP66	



Technical data

3.2.2 Type GHG02611-5

Specification	Value	Unit
Weight	8,200–9,200	kg*
Length	400	mm
Width	268	mm
Height	180	mm

Electrical connection values

Specification	Value	Unit
Supply voltage	115/230	V AC
Supply current, maximal	2	A
Power consumption, maximal	125	W
External fuse** (delayed action)	3	A
Protection	IP66	

- Depending on engine cylinder numbers:
 - 8,200 for engines with 4–7 cylinders
 - 9,200 for engines with 8–14 cylinders

** Not part of Dr. Horn's scope of supply

3.3 Terminal box GHG02621-3

Specification	Value	Unit
Weight	4,000	kg
Length	300	mm
Width	190	mm
Height	128	mm

Electrical connection values ***

Specification	Value	Unit
Supply voltage	24	V DC
Supply current, maximal	1	A
Power consumption, maximal	0,2	W
Protection	IP66	front



3.4 Distance sensor IW000184

Specification	Value	Unit
Weight	0,120	kg
Length	132	mm
Diameter	19	mm
Linear measuring range	2...6	mm
Temperature measurement range	0...+70	°C

Electrical connection values

Specification	Value	Unit
Supply voltage	+15...30	V DC
Current consumption	50	mA
Short-circuit protected		
Protection degree	IP67	

Environment

Specification	Value	Unit
Temperature range	0...+70	°C
Target	24x24x1 steel acc. to S235	mm



Technical data

3.5 Water-in-oil sensor FRG00032-6_AW

Specification	Value	Unit
Weight	0,328	kg
Length	186.5	mm
Diameter, maximal	60	mm

Electrical connection values ***

Specification	Value	Unit
Supply voltage	24	V DC
Current consumption	50	mA
Protection	IP65	
Output current, maximal	200	mA SCP

Environment

Specification	Value	Unit
Temperature range	0 - +85	°C
Pressure resistance against medium	10	bar



3.6 Main bearing temperature sensor TGL00921/TGL00921-1

Specification	Value	Unit
Weight	0,200	kg
Length	50	mm
Width	22	mm
Height	6	mm

Electrical connection values ***

Specification	Value	Unit
Supply voltage	24	V DC
Current consumption	50	mA
Protection	IP67	

Environment

Specification	Value	Unit
Temperature range	-10 - +90	°C
Connection cables	4 x 0,34	mm ²

*** Power 24VDC is supplied through the Line converter box GHG02611 -4 or -5

3.7 Emissions

There are no emissions expected.



Structure and function

4 Structure and function

4.1 Overview

This overview Fig. 1 is valid for principal installation on 6S50MC-C.

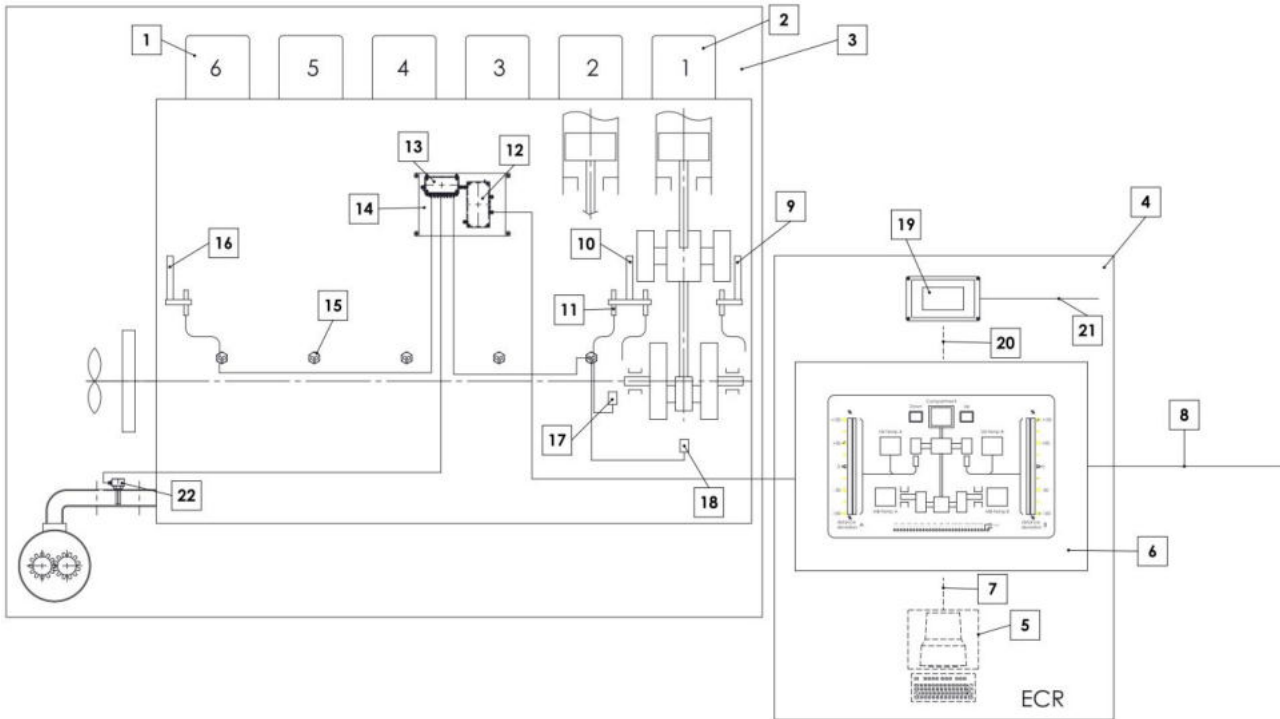

Fig. 1: System overview

- | | | | |
|----|-------------------------------------|----|---|
| 1 | Cylinder number 6 | 12 | Line Converter box GHG02611-4/-5 |
| 2 | Cylinder number 1 | 13 | Terminal box GHG02621-3 |
| 3 | Engine room | 14 | Mounting bracket with boxes
BLG00402/BLG00403 |
| 4 | Engine control room | 15 | Cable gland KV000xxx |
| 5 | Personal computer (customer supply) | 16 | Bracket HAG00xxx |
| 6 | Indication unit MDA312... | 17 | Temperature sensor for main bearing
TGL00921 |
| 7 | Connection cable LT02012D0 | 18 | Temperature sensor for splash oil TGL00921-1 |
| 8 | Power supply | 19 | User Interface EV314013 |
| 9 | Bracket HAG00xxx | 20 | Connection cable for EV314013 to MDA312... |
| 10 | Bracket HAG00xxx | 21 | Connection cable for sensor IW000184
KSG03252-15 |
| 11 | Sensor IW000184 | 22 | Water-in-oil sensor FRG00032-6_AW |



4.2 Brief description

The Bearing Distance and Temperature Monitoring System (BDMS/BTMS) is a system that allows the continuous control of the distance between the surface of the distance sensor and the crosshead in the bottom dead centre of a 2-stroke diesel engine.

Additionally the sensor is able to measure the temperature of the splash oil around its location. Measured values are calculated into real distance values in mm and °C by the sensor stored in an internal memory inside the sensor.

Another optional sensor is able to measure the water content in the lube oil. It is called the water-in-oil sensor. This sensor is installed in the pressure line close to the engine.

The BDMS/BTMS can be installed as a retrofit into engines already in service.

The BDMS/BTMS is Type Approved by Germanischer Lloyd (GL) and other classification societies.

All sensors transfer the respective measured values via Terminal boxes to a Line Converter box and into the Indication unit.

Mainly the BDMS/BTMS consists of the following components:

- Sensors
- Sensor brackets
- Terminal box
- Line Converter box
- Indication unit



Structure and function

4.3 Description of assemblies

4.3.1 Sensors

There are a few sensors that can be assembled within the system. Some of them are within scope of supply, some are optional:

- Distance sensor
- Water-in-oil sensor (optional)
- Main bearing temperature sensor (optional)
- Splash oil temperature sensor (optional)

4.3.1.1 Distance sensor



Fig. 2: Distance sensor

- Item no.: IW000184

The distance sensor type IW000184 (Fig.2) with protection degree IP67 and electrical short circuit protection is an intelligent high-speed dual sensor of the Bearing Monitoring System - BMS. It is able to measure the distance in a range between 2.0...6.0 mm with a high resolution of 0.01 mm. Additionally it measures the splash oil temperature in the area around the sensor within the range of 0...+70 °C at a tolerance of +/- 2 °C.

The sensor detects the crosshead within his distance range and calculates the lowest air gap in mm. The value is stored in an internal buffer and updated constantly at every revolution.

On request of the Indication unit which acts as a master the buffer information is delivered via the serial link (Terminal box > Line Converter box > Indication unit) and compared against limits by software.

The sensor has no thread; the fastening in the engine is arranged by clamping in the brackets. For correct installation to the serial net the sensor is marked with a special ID allowing the installer to identify the sensor to ensure that fwd- and aft-sensor per cylinder is connected correctly to the network. Additionally the sensor has a LED under the connection point indicating correct power supply.

For connection to the outside through the cable glands in the engine wall the sensor is delivered with an angle connector and 15 m oil resistant PUR cable. By this connection an easy exchange is possible in case an exchange should become necessary.

Measured values are transferred as a RS232 signal via the Terminal box to the Line Converter box.



4.3.1.2 Water-in-oil sensor

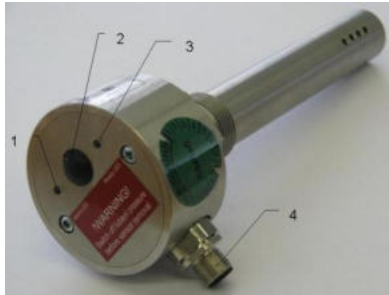

Fig. 3: Water-in-oil sensor

■ Item no.: FRG00032-6_AW

- 1 Alarm LED
- 2 Function test button
- 3 Ready LED
- 4 Connection

The water-in-oil sensor (Fig. 3) is designed to monitor the amount of water in the engine lube oil. The measuring principle is the change of the dielectric value of the oil due to the water content. The capacitive design recognizes these changes and the built-in microprocessor calculates the values for pre-warning and alarm threshold. Default values are 0.5 and 0.9aw. For further Information please see the WaterInOil BDMS Manual DK002112.

This sensor has to be installed in the pressure line or near the engine (pressure outlet of the lube oil filter) in a non turbulence area (behind the filter unit) inside the oil stream.

Measured values are transferred as a RS232 signal via the Terminal box to the Line Converter box.

A green and a red LED indicate a special status:

Green LED	Red LED	Indication
flashing	off	water content less than 0.5aw
flashing	flashing	water content between 0.5 and 0.9aw
flashing	on	water content higher than 0.9aw
off	off	fault or sensor not connected



Structure and function

4.3.1.3 Temperature sensor for main bearing (optionally available)

- Item no.: TGL00921



Fig. 4: Main bearing temperature sensor

The temperature sensor for main bearing type TGL00921, with electrical short circuit protection (Fig. 4/1) is an optional component. It can be ordered separately. The main bearing temperature sensor is designed to measure the splash oil temperature out of the main bearing. The minimised flat design allows mounting the sensor at the main bearing support close to the bearing shell.

The temperature sensor can easily be placed at the support with the help of internal magnetos. When correctly placed it must be secured by oil resistant glue.

The temperature data are measured within a tolerance of +/- 1.5 °C and transferred via the serial link of the BDMS/BTMS to the Indication unit. The refreshment of these measured values is made with a lower priority within every 1500 ms. The maximum operating temperature is 90 °C, for short time 115 °C. If a bearing has been overheated above the short time tolerable value the sensor has to be replaced.

4.3.1.4 Temperature sensor for splash oil (optionally available)



Fig. 5: Splash oil temperature sensor





The temperature sensor for splash oil type TGL00921-1, with electrical short circuit protection (Fig. 5/1) is an optional component. It can be ordered separately. The main bearing temperature sensor is designed to measure the splash oil temperature in the crankshaft housing.

The temperature sensor can be easily placed on the engine whole in the near of the crankshaft with help of internal magnetos. When correctly placed it must be secured by oil resistant glue.

The temperature data are measured within a tolerance of +/- 1.5 °C and transferred via the serial link of the BDMS/BTMS to the Indication unit. The refreshment of these measured values is made with a lower priority within every 1500 ms. The maximum operating temperature is 90 °C, for short time 115 °C. If a bearing has been overheated above the short time tolerable value the sensor has to be replaced.

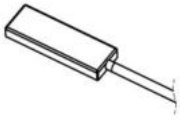
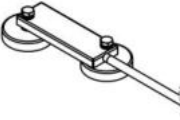

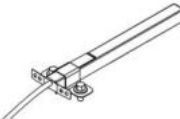
4.3.1.5

<p>TGL00921</p> 	<p>Temperature sensor</p>	<p>The sensor shall be fixed to a flat and oil clean surface with oil resistant glue Loctite 5970. Take care that there is a good connection between sensor and the flat engine surface. The magnets inside of the sensor help to fix the sensor during the glue process. Secure the cable with cable clips/glands delivered in the assembly package.</p>
<p>TGL00921-1</p> 	<p>Splash oil temperature sensor</p>	<p>The sensor must be fixed to a flat and oil clean surface with oil resistant glue Loctite 5970. Take care that there is a good connection between sensor and the flat engine surface. The magnets of the sensors help to fix the sensor during the glue process and give distance between the mounting surface and the sensor itself. Secure the cable with cable clips/glands delivered in the assembly package.</p>
<p>TGL00921-2</p> 	<p>Main bearing temperature sensor</p>	<p>At first mount the spring clip with screws and a pair of locking washer for each screw. Here push the sensor under the spring clip together with oil resistant glue and push the sensor so far, that the end of the sensor connects to the engine surface and check that all areas are glued. Secure the cable with cable clips/glands delivered in the assembly package.</p>
<p>TGL00921-3</p> 	<p>Thrust bearing temperature sensor</p>	<p>At first glue the sensor to a flat and clean surface of the engine. Mount the spring clip with screws and a pair of locking washer on top of the sensor. Secure the cable with cable clips/glands delivered in the assembly package.</p>
<p>TGL00921-4</p> 	<p>Splash oil bearing temperature sensor</p>	<p>At first tighten the pipe fitting with 25 Nm at the engine housing. Then push the sensor pipe through the fitting to the defined position and fix it. Take care to select the right position because the sensor cannot be moved to another position after fixing. The sensor electronic must be fixed to flat and oil free surface with oil resistant glue Loctite 5970. Take care that there is a good connection between sensor and the flat engine surface. Secure the cable with cable clips/glands delivered in the assembly package.</p>



Structure and function

4.3.2 Sensor brackets

The sensor brackets guarantee a correct and vibration-free installation of the distance sensors.

Depending on the type of engine either

- tube type sensor brackets or
- profile type sensor brackets

have to be mounted.



NOTE!

A table indicating the different types of engine and the respective sensor brackets is given in the chapter "Mounting the sensor brackets".



NOTE!

Optional deviant fixing material is listed at the „Approval drawing“

4.3.2.1 Tube type sensor brackets

- Item no.: HAG00xxx (depending on engine type)

The single sensor bracket (Fig. 5) is mounted on both sides under the crosshead sliding plate. Therefore a mounting surface has to be made about 2 mm more in diameter than the bracket to allow a correct vertical and horizontal placing. In the centre a threaded hole with M10 or M12 is needed to fix the bracket in place with a high tensile M10 bolt with a torque moment of 70 Nm, or a M12 bolt with a torque moment of 120 Nm. This bracket can be turned to place the sensor correctly under the crosshead.

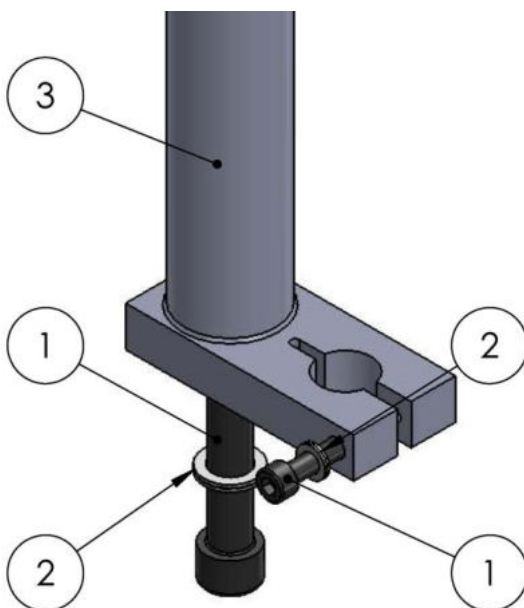

- 1 Bolt
- 2 Nord-Lock® disc
- 3 Sensor bracket

Fig. 5: Single sensor bracket



4.3.2.2 Profile type sensor brackets

There are two different types of profile type sensor brackets:

- Single profile type sensor bracket for one distance sensor
- Double profile type sensor bracket for two distance sensors

Single sensor bracket

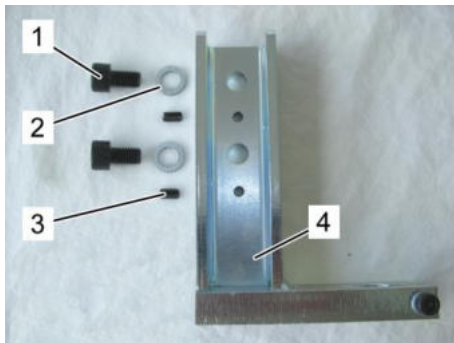
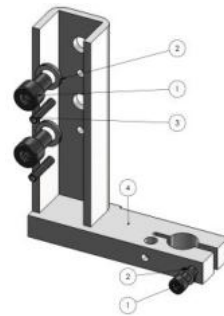

Fig. 6: Single profile type sensor bracket type HAG00xxx-L

- Item no.: HAG00xxx-L (depending on engine type)
- Item no.: HAG00xxx-R (depending on engine type)

- 1 Bolt
- 2 Nord-Lock® disc
- 3 Alignment pin
- 4 Sensor bracket



The single sensor bracket for one sensor is placed under the crosshead of the first (HAG00xxx-L, Fig. 6) and the last cylinder (HAG00xxx-R, Fig. 7) because there only one distance sensor has to be mounted.

The single sensor brackets are mounted by two M8 or M10 bolts.

Recommended :

For a higher accuracy, alignment pins can be used. After the sensor bracket is installed correctly with the two bolts, the two holes for the alignment pins can be drilled and the pins inserted. The pins ensure a correct positioning of the sensor bracket and are part of delivery.

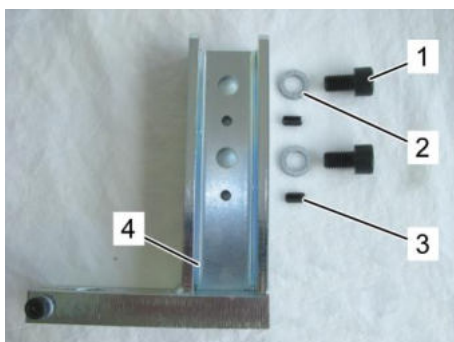
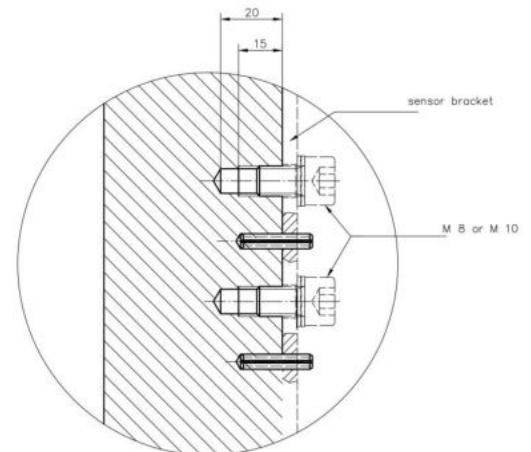
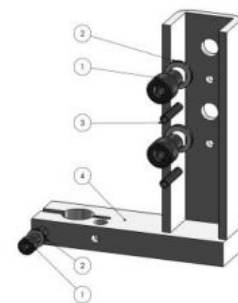

Fig. 7: Single profile type sensor bracket type HAG00xxx-R

- 1 Bolt
- 2 Nord-Lock® disc
- 3 Alignment pin
- 4 Sensor bracket



All dimensions in mm



Structure and function

Double sensor bracket

■ Item no.: HAG00xxx (depending on engine type)

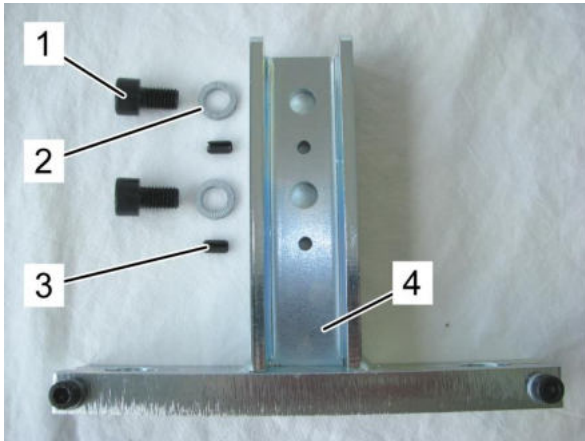

- 1 Bolt
- 2 Nord-Lock® disc
- 3 Alignment pin
- 4 Sensor bracket

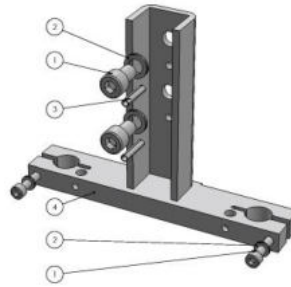
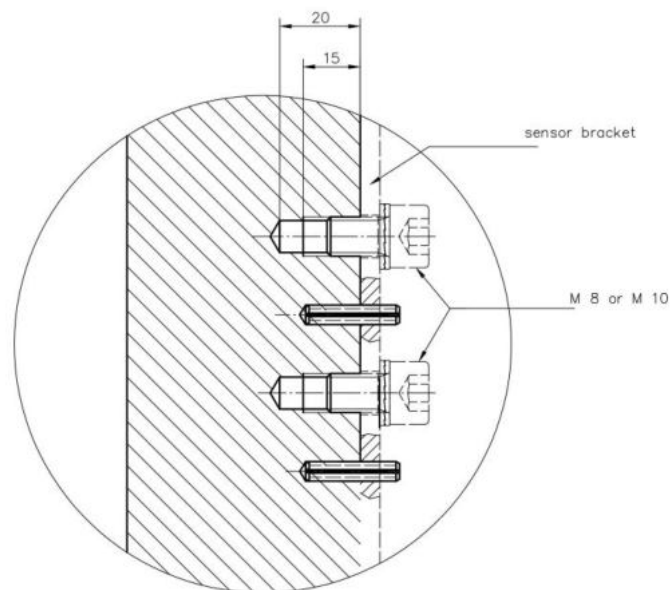

Fig. 8: Double profile type sensor bracket type HAG00xxx

The double sensor bracket for two sensors (Fig. 8) must be placed in the centre under the crosshead sliding plate. Therefore two M8 or M10 bolts are needed.

Recommended :

For a higher accuracy, alignment pins can be used. After the sensor bracket is installed correctly with the two bolts, the two holes for the alignment pins can be drilled and the pins inserted. The pins ensure a correct positioning of the sensor bracket and are part of delivery.



All dimensions in mm



4.3.3 Terminal box

- Item no: GHG02621-3



Fig. 9: Terminal box closed

A Terminal box includes the connection board which is needed to connect the sensors and to deliver the necessary galvanic power received from the Line Converter box to the sensors. On the other hand they establish the serial data link from the sensors to the Line Converter box.

In one Terminal box up to 17 sensors can be assembled, for example 14 distance sensors and one water-in-oil sensor for a seven-cylinder engine. If more sensors are installed in a system a second Terminal box has to be installed. This is necessary when the BDMS/BTMS is installed in an engine with more than seven cylinders or additional main bearing temperature sensors are installed too.



NOTE!

Inside the Terminal box the distance sensors, water-in-oil sensors and the main bearing temperature sensors can be connected to any available connector without following a routine.



Fig. 10: Terminal box opened

A green LED and an electronic fuse are placed on the board at every connection socket for each of the 17 sensors. The LED indicates correct power supply. The fuse protects all other connections and connected units in case of a short circuit in one of the connected sensors.



Structure and function

4.3.4 Line Converter box

- Item no.: GHG02611-4 for 24 V DC supply
- Item no.: GHG02611-5 for 115/230 V AC 50/60 cycle supply

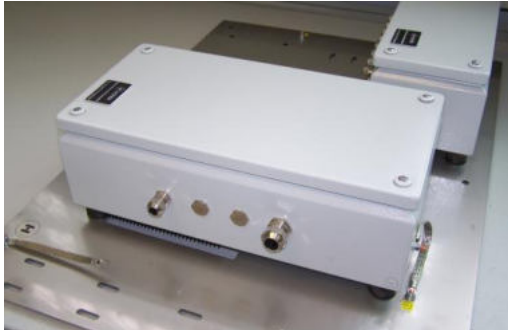

Fig. 11: Line Converter box closed

The Line Converter box (Fig. 11) delivers the galvanic isolated power and receives the data from all sensors connected to the system. The RS232 data from the sensors are changed into RS422 in the Line Converter box and transferred to the Indication unit.

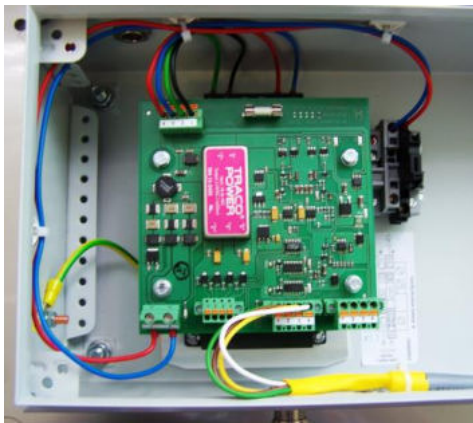

Fig. 12: Line Converter box type GHG02611-4 opened

Fig. 12 shows a Line Converter box for maximal 60 sensors.



4.3.5 Indication unit

The Indication unit presents data from all connected sensors within a certain priority chain. The measured values are compared against limits given by the engine manufacturer. Pre-alarm/load reduction relays are available for selection by the user.

Received data are stored in a normal SD card. The so called short term storage allows the view of the last 24 hours in real time. The long term storage contains maximum, minimum and average values for every 6 running hours. The event log contains alarms, slow downs and other important informations. Storage capacity is about 10 years. For the purpose of presentation to surveyors from classification societies one xml file can be made.

The customer can connect the USB link of the unit to any engine PC (not supplied by Dr. E. Horn) and additionally store the data here.

For this storage as well as for special views to the behaviour of the bearing wear a programme called LagMon is optionally available from Dr. E. Horn. If this programme is installed the crew/superintendents/classification surveyors and service specialists can easily track the wear record and download the values.

The Indication unit is available in two executions:

- Mounted in field housing for direct installation in the engine room or the engine control room
- Mounted in a switchboard panel or engine control console

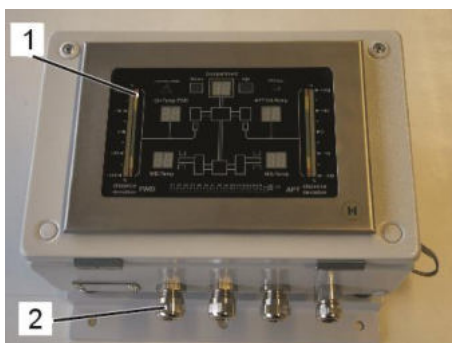

Fig. 13: Indication unit with field housing

Indication unit to be mounted inside the engine room

- Item no.: MDA312...
- Protection class: IP66

- 1 Display
- 2 Connections with cable glands

The Indication unit to be installed inside the engine room has cable glands (Fig. 13/2) allowing the connection of:

- serial link bus cable
- 24 V power supply
- connection of the USB to ship or engine PC
- relay outputs



Structure and function

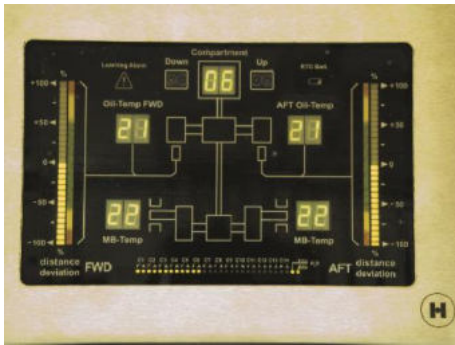

Fig. 14: Indication unit for control console

Indication unit to be mounted in a switchboard panel or control console

- Item-no.: MDA312...
- Protection class front: IP66
- Protection class back: IP20

The Indication unit to be installed in a switchboard panel or a control console has all connections on its back secured by connectors. They allow the connection of:

- serial link bus cable
- 24 V power supply
- connection of the USB-Serial Port to ship or engine PC (not part of delivery from Dr. E. Horn)
- relay outputs



4.4 Connections

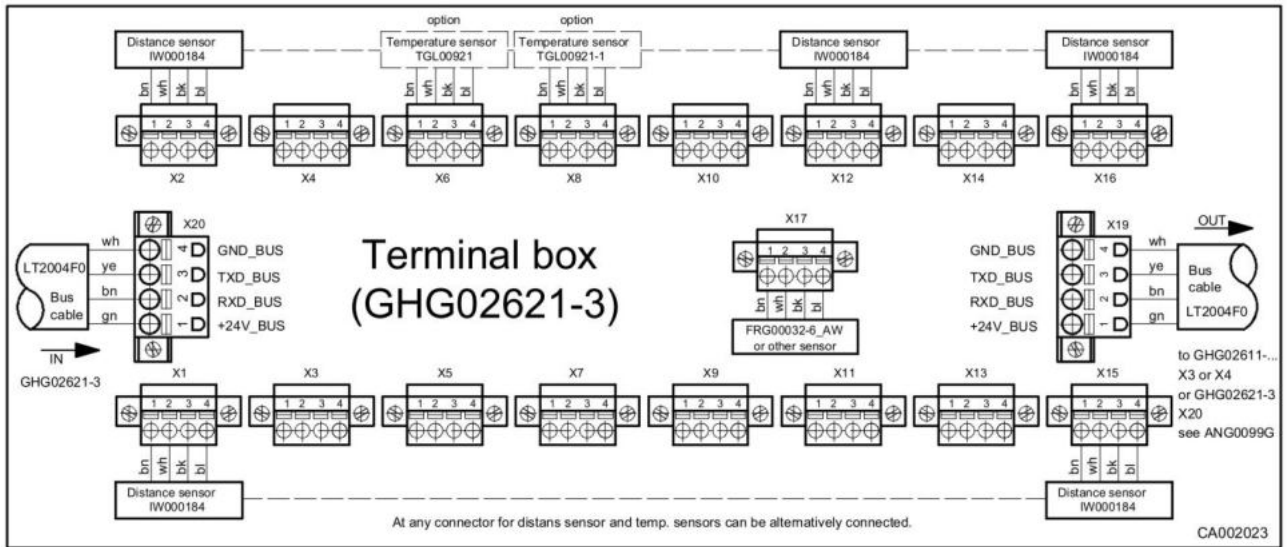

Fig. 15: Connection plan Terminal box GHG02621-3 (proposal)

- depending on the position of the Terminal box

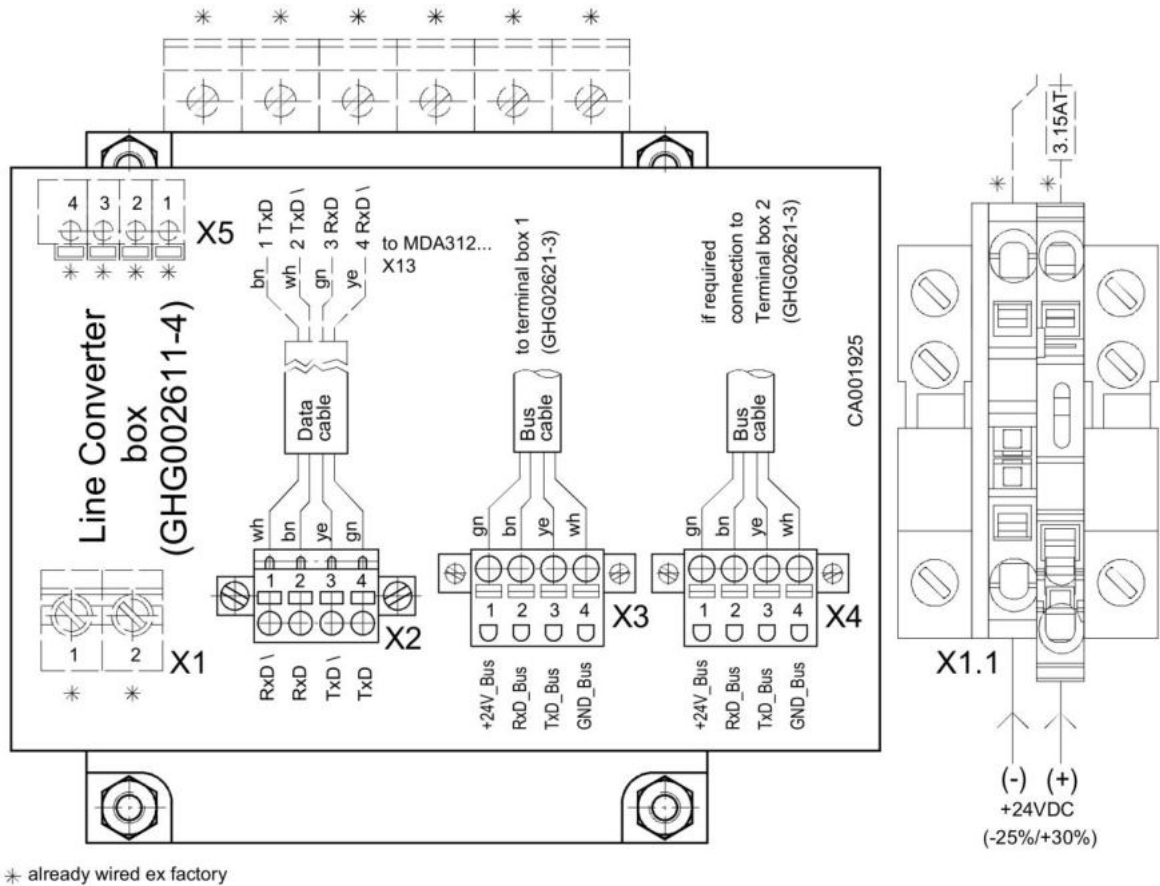

Fig. 16: Connection plan Line Converter box GHG02611-4



Structure and function

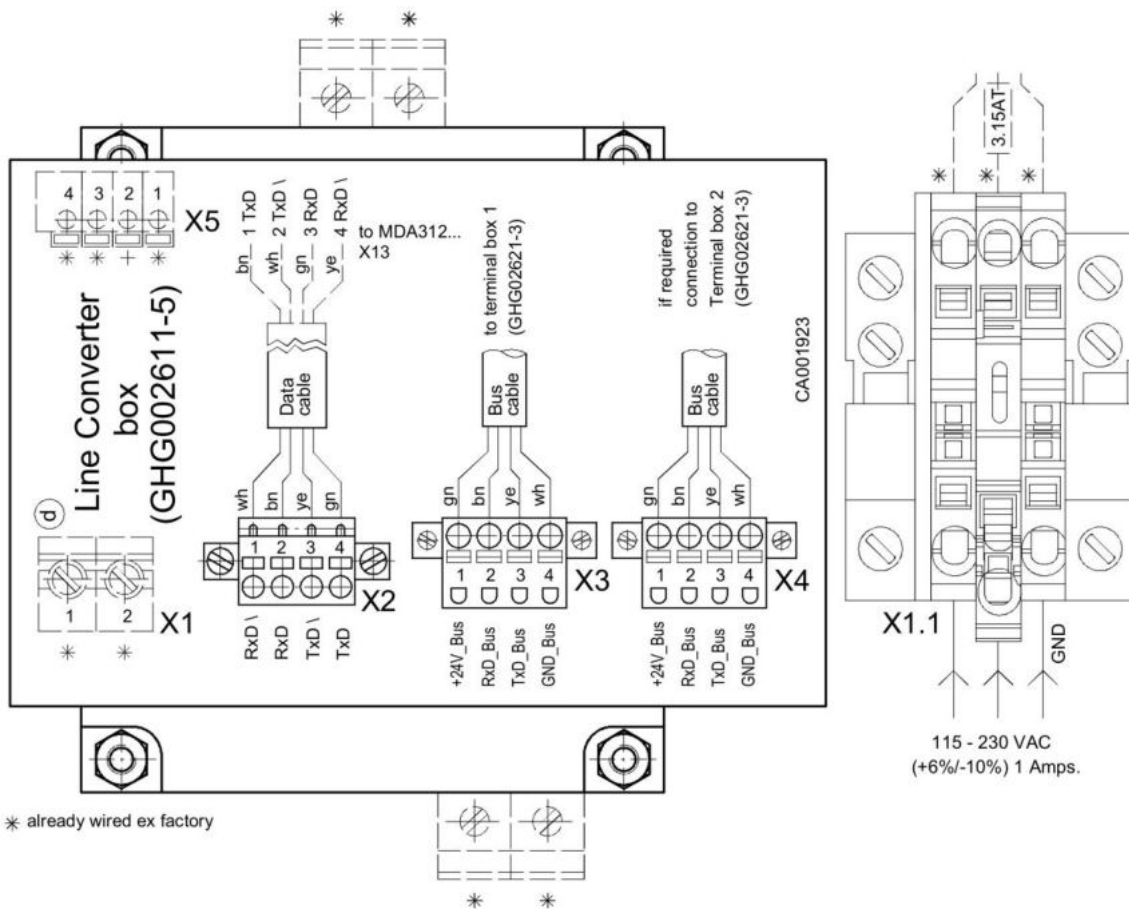

Fig. 17: Connection plan Line Converter box GHG02611-5

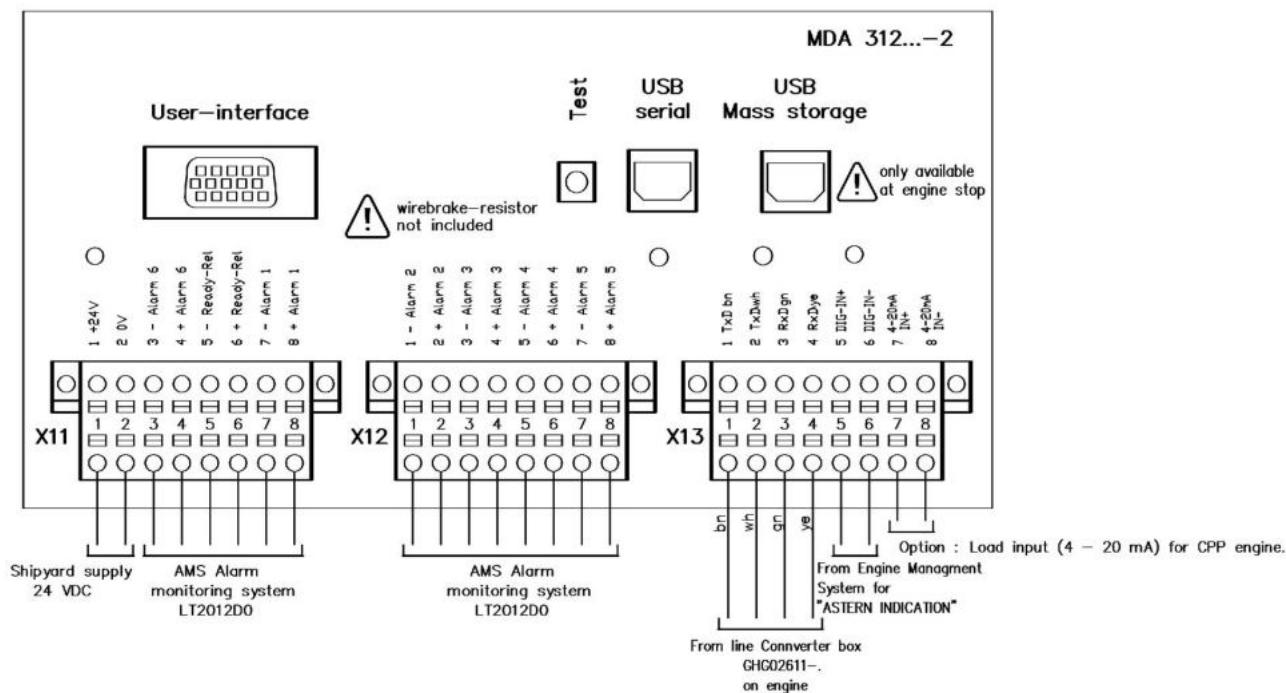

Fig. 18: Connection plan Indication unit MDA312-2

4.5 Work and danger zones

Work and danger zones may only be mentioned because these zones depend on the position and the environment in which the components of the system are mounted.

Work zones

- In front of the Indication unit
 - in the control room
 - in the engine room

Danger zones

- Inside the engine (Fig. 19/1)
- Inside the engine room (Fig. 19/2)

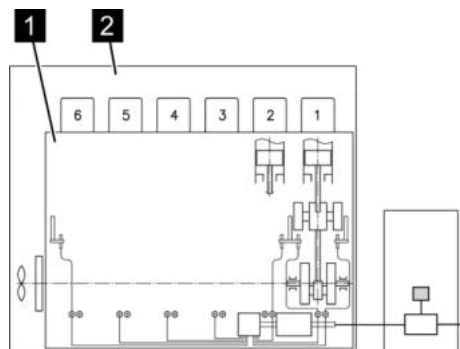

Fig. 19: Danger zones



Structure and function

4.6 Operating elements

The design of the Indication unit may differ depending on the components installed in the system.

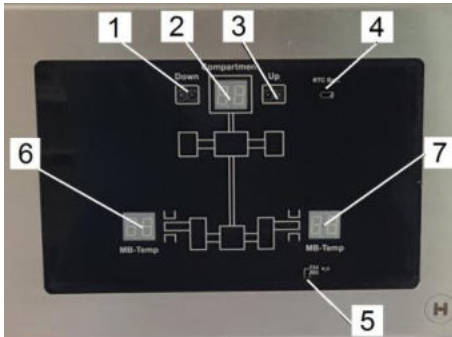

Fig.20: Indication unit, BTMS

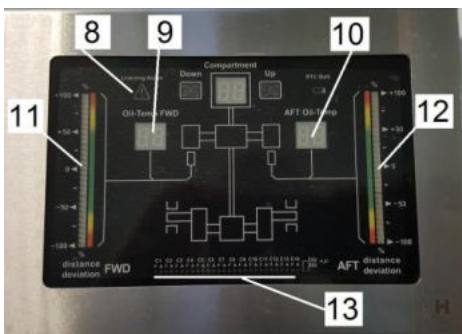

Fig.21: Indication unit, BDMS

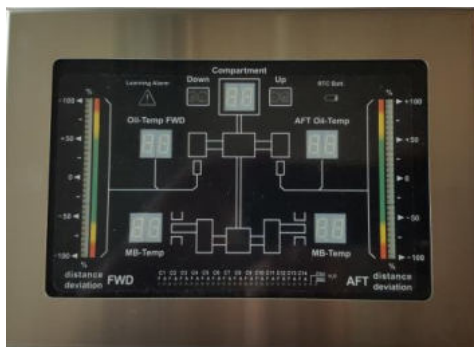

Fig. 22: Indication unit, BDTMS

The **BDTMS** indication unit is a combination from **BTMS** and **BDMS**

The **BDTCMS** indication unit is the **BDTMS** unit plus the splash oil temperature sensor

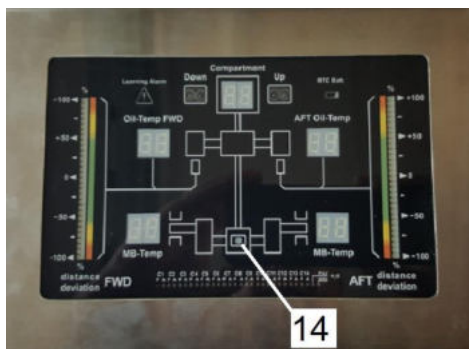

Fig. 23: Indication unit, BDTCMS

All available components

- 1 Optical button "Down"
- 2 Compartment number
- 3... Optical button "Up"
- 4 Real-Time-clock battery level low
- 5 LED indicating installed H₂O sensor
- 6 Main bearing temperature
- 7 Main bearing temperature
- 8 Learning alarm
- 9 FWD distance sensor (crosshead splash oil) temperature
- 10 AFT distance sensor (crosshead splash oil) temperature
- 11 Measured by FWD distance sensor deviation
- 12 Measured by AFT distance sensor deviation
- 13 LED indicating the number of installed distance sensors
- 14 Conrod splash oil temperature sensor status



5 Transport, packing and storage

5.1 Safety notes for transport

Suspended loads

**WARNING!****Life-threatening hazard due to suspended loads!**

When lifting loads a life-threatening hazard is posed by falling loads or swinging parts.

Therefore:

- Never position yourself under a suspended load!
- Heed the instructions concerning the intended lifting points.
- Do not attach to projecting machine components or to the eyes of attached components; ensure that the sling gear is securely seated.
- Only use approved lifting gear and slings with sufficient bearing capacity.
- Do not use frayed or scored rope or belts.
- Do not lay ropes and belts on sharp edges and corners, do not knot or twist ropes and belts.

Eccentric center of gravity

**WARNING!****Danger of falling due to eccentric center of gravity!**

Packing crates can have an eccentric center of gravity. The wrong kind sling gear attachment can tilt the packing crate and cause life-threatening injuries.

Therefore:

- Comply with the instructions marked on packing crates.
- Attach the crane hook in such a manner that it is over the center of gravity.
- Lift carefully and observe if the load tips. If required change the position of the sling gear.



Transport, packing and storage

Improper transport



CAUTION!

Improper transport can result in damage!

Improper transport can cause extensive material damage.

Therefore:

- When unloading the packing units upon delivery and during in-house transport, exercise caution and observe the symbols on the package.
- Use only the provided attachment points.
- Do not remove packaging material until units are ready for assembly.

5.2 Transport inspection

Check the delivery immediately on receipt for completeness and transport damage.

If externally detectable transport damage is found, proceed as follows:

- Do not accept the delivery, or only with reservation.
- Record the extent of transport damage in the transport documents or on the delivery note of the forwarding agent.
- Start complaints procedure.



NOTE!

Claim any damage as soon as it is detected. Compensation claims can only be submitted within the applicable complaints periods.

5.3 Transport

Transport of packages by crane

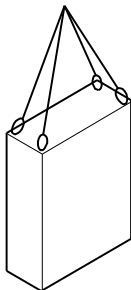

Fig. 20

Packages with lifting eyes can be transported by crane under the following conditions:

- Crane and lifting tackle must be sufficiently dimensioned for the weight of the package.
- The operator must have authorization for operating the crane.

Hooking up:

1. Fasten ropes, belts or multi-point tackle as shown in Fig. 20.
2. Make sure that the package is hanging straight, if necessary observe an eccentric centre of gravity.
3. Start transport.

**Transport of pallets by crane**

Fig. 21

Packages on pallets can be transported by crane under the following conditions:

- Crane and lifting tackle must be sufficiently dimensioned for the weight of the package.
- The operator must have authorization for operating the crane.

Fastening lifting tackle:

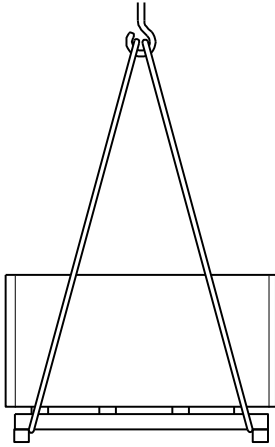
1. Fasten ropes, belts or multi-point tackle on the pallet as shown in Fig. 21.
2. Make sure that the package will not be damaged by the lifting tackle. If necessary use other lifting tackle.
3. Start transport.

Transport of pallets by forklift truck

Fig. 22

Packages on pallets can be transported by forklift truck under the following conditions:

- The forklift truck must match the weight of the transport units.
- The operator must have authorization for operating the forklift truck.

Picking up:

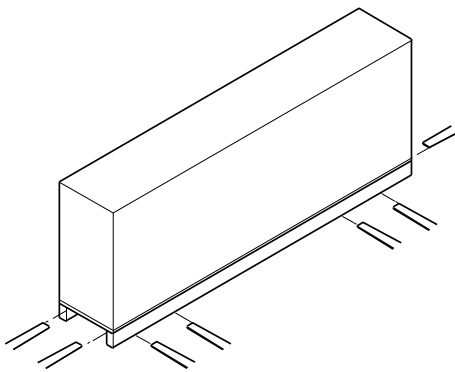
1. Insert the forks of the forklift truck between or under the pallet beams.
2. Insert the forks until they appear on the opposite side.
3. Make sure that pallets with eccentric centre of gravity will not tip over.
4. Lift the package and start transport.

5.4 Packing**Concerning packing**

The individual packages have been packed to match the transport conditions that can be expected. Only environmentally friendly materials were used for packing.

The packing has the function of protecting the individual components against damage, corrosion, etc., until they are finally assembled. The packing material must therefore not be damaged and should only be removed just before assembly takes place.



Transport, packing and storage

Handling packing materials

If there is no returns agreement for the packing, separate materials according to type and size and direct to further use or recycling.



CAUTION! **Environmental damage caused by incorrect waste disposal!**

Packing materials are valuable raw materials and can continue to be used in many cases or sensibly reconditioned and recycled.

Therefore:

- Dispose of packing materials environmentally.
- Follow the locally valid waste disposal regulations. If necessary employ a special waste disposal company to dispose of packing material.

5.5 Storage

Storage of packages

Store packages under the following conditions:

- Do not store outdoors.
- Store in a dry and dust-free environment.
- Do not subject to aggressive media.
- Protect against direct sunlight.
- Avoid mechanical vibrations.
- Storage temperature: 15 to 60 °C.
- Relative air humidity: max. 60 %.
- For storage periods longer than 3 months check the general condition of all parts and packaging regularly. If necessary refresh or renew the conservation.



NOTE!

Packages may be marked with notes for storage, which may exceed the requirements mentioned here. These must be adhered to.



6 Installation, fixing and commissioning

6.1 Safety

Personnel

- Installation and commissioning may be executed only by qualified personnel.
- All work on the electrical system must be performed by a qualified electrician.

Personal protective equipment

Wear the following personal protective equipment at all installation and commissioning work:

- Protective clothing
- Safety boots
- Hard hat

Wear the following personal protective equipment when entering the engine room:

- Protective gloves
- Safety belt if it is necessary to bridge big heights



NOTE!

Other personal protective equipment that has to be worn at particular work will be mentioned in the warning notices in this chapter.

Electrical system



DANGER!

Danger to life due to electric current!

A life-threatening hazard exists if there is contact with live components. Switched on electrical components can execute uncontrolled movements and cause the most serious injuries.

Therefore:

- Prior to starting work switch off the power supply and safeguard it from being switched on again.



Installation, fixing and commissioning

Engine

**WARNING!****Danger to life caused by engine in progress!**

Starting the engine while working on or inside of it may cause very serious injury or even lead to death.

Therefore:

- Switch off the engine before performing any installation work and make sure that it cannot be switched on accidentally.

**WARNING!****Danger of injury due to improper installation and commissioning!**

Improper installation and commissioning can result in severe personal injury or material damage.

Therefore:

- Prior to beginning installation, ensure that there is sufficient space to work.
- Handle open sharp-edged components with care.
- Make sure that the assembly location is clean and well organized. Components that are loosely stacked or lying around can cause accidents.
- Assemble components properly. Comply with specified screw tightening torques.
- Secure components so that they cannot fall or tip over.

Securing against switching on

**DANGER!****Danger to life caused by uncontrolled switching on again!**

There is a risk of the electric power supply being switched on again when installing the device. This imposes danger to the life of persons in the danger zone.

Therefore:

- Before starting work, switch off all power supplies and secure against switching on again.



6.2 Preparations

Cable glands

**CAUTION!**

Damages to cables caused by sharp hole edges!

The cables might get damaged by sharp edges when they are guided through the holes.

Therefore:

- Insert two cable glands one inside and one outside the engine crankcase.
- Have defective cable glands repaired immediately.

Before beginning with the installation of the BDMS/BTMS the cable glands (Fig. 24) have to be mounted into the drillings.

6.2.1 Preparing the installation into new engines under assembly

Drillings

All necessary drillings for the installation of the BDMS/BTMS and the mounting of the cable glands already exist.

In new engines under construction each sensor has its own cable gland. Therefore only cable glands of type "A" are used.

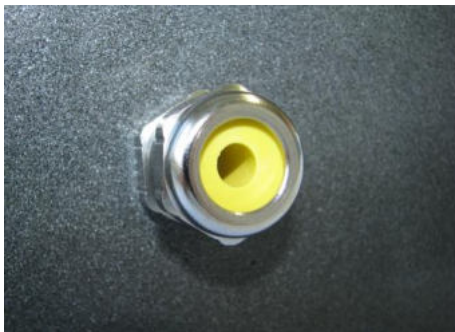

Fig. 23: Cable gland type "A"

1. Insert the cable glands type "A" (Fig. 23, M20x1.5) into the drillings from the first to the last cylinder. One cable gland inside and one cable gland outside of the engine wall!

**NOTE!**

The number of cylinders depends on the type of engine. Therefore the number of cable glands that have to be mounted may differ.



Installation, fixing and commissioning

6.2.2 Preparing the installation as a retrofit

- Required tools:
 - Core-hole drill 18.5 mm
 - Thread drill M20x1.5 mm

When the system is installed as a retrofit into engines already in service cable glands with one, two or more outlets are used for leading the cables out of the engine.

Drillings

The respective holes have to be drilled into the engine wall before the cable glands are inserted.

1. Drill the holes with the core-hole drill (18.5 mm) into the engine wall according to the drawings.
2. Use the thread drill to insert the thread M20x1.5 into the holes.
3. Insert the cable glands type "B" (Fig. 24, M20x1.5) into the drillings at all cylinders; one cable gland inside and one outside the crankcase.



Fig. 24: Cable gland type B



NOTE!

The number of cylinders depends on the type of engine. Therefore the number of cable glands that have to be mounted may differ.



6.3 Installation

6.3.1 Preface

Preparing cables

The following sections describe general aspects which are significant for the correct installation of the device.

Cables have to be prepared before they can be assembled in the system.

1. Remove the outer sheath of the cable

Fig. 27/1) to such an extent that the spring

Fig. 27/3) inside of the cable glands may come to lie on the naked screen

Fig. 27/6). For assembly compress the spring (Fig. 27/3) slightly and insert in cable gland casing (Fig. 27/2)

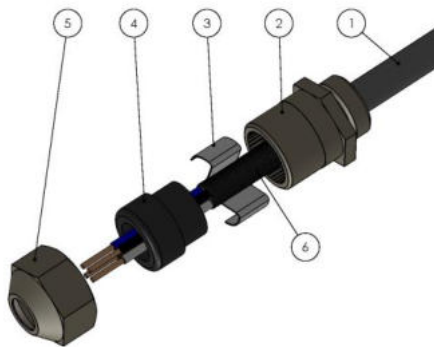

Fig. 25: Screen of a cable



NOTE!

It is also possible to remove only a small ring of the outer sheath at that point where the spring is in its final position in the cable gland.

But it is necessary that the spring is in full contact with the screen. The screen itself can be led into the box.

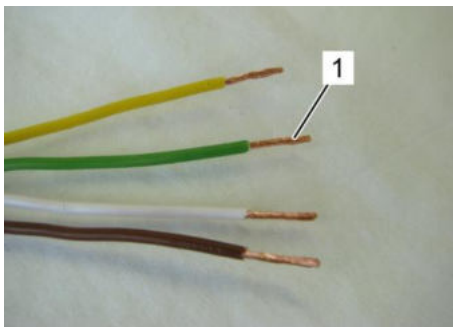

Fig. 26: Stripping insulation

4. Strip the insulation of each conductor (Fig. 26/1) to approximately 1 cm.



Installation, fixing and commissioning



CAUTION!

Danger of short-circuit due to improperly connected cables!

Conductors that contact each other may short-circuit. This may cause damages to the device.

Therefore:

- Connect each conductor of a cable to its connector with cable lugs.
- Make sure the wires of the conductor do not contact each other.

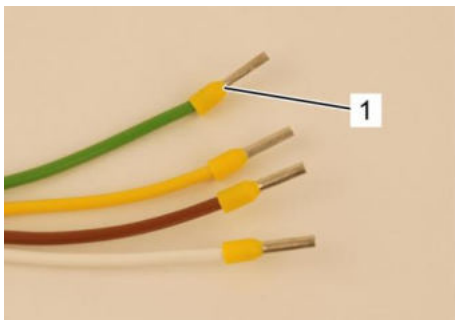

Fig. 29: Cable lug

5. Put each conductor into a suitable cable lug (Fig./1) and squeeze it.

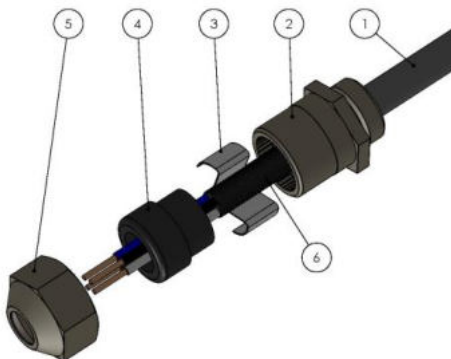

Fig. 27: Assembly of a cable gland

6. Assemble the cable gland according to Fig. 27.



NOTE!

The spring of the cable gland (Fig. 27/3) has to lie on the naked screen (Fig. 30/6) of the cable. For assembly compress the spring (Fig. 27/3) slightly and insert in cable gland casing (Fig. 27/2)



6.3.2 Mounting the sensor brackets

- Construction only by qualified personnel.
- Additionally required protective equipment:
 - Hard hat
 - Safety boots
 - Safety belt if it is necessary to bridge big heights
- Required tools:
 - Torque wrenches with hexagon insert 5, 6, 8, and 10
 - Hammer
 - 5 mm drill (for the alignment pin holes necessary at the profile type sensors)

Types of sensor brackets

Depending on the type of motor two different types of sensor brackets may have to be installed:

- Tube type sensor brackets
- Profile type sensor brackets two sensors

The following table shows the type of brackets to be used depending on the type of engine. (further configuration available)

Engine type	Number of cylinders	Tube type bracket	Profile type bracket	Nord-Lock®
S26 MC6	5-12	x		
L35 MC6	5-12	x		
S35 MC7	5-12	x		
S35 ME-B9	5-8		x	2xM10
S40 ME-B9	5-8		x	2xM10
S42 MC7	5-12	x		
S46 MC-C7	5-8		x	2xM10
S46 MC-C8	5-8		x	2xM10
S50 MC-C7	5-9		x	2xM10
S50 MC-C8	5-9		x	2xM10
S50 MC6	5-8	x		1xM10
S50 ME-B8	5-9		x	2xM10
S50 ME-C7	5-9		x	2xM10



Installation, fixing and commissioning

Engine type	Number of cylinders	Tube type bracket	Profile type bracket	Nord-Lock®
S50 ME-C8	5-9		x	2xM10
L60 MC-C7	5-9		x	2xM10
L60 MC-C8	5-9		x	2xM10
S60 ME-C7	5-8		x	2xM10
S60 ME-C8	5-8		x	2xM10
S60 MC6	5-8	x		1xM10
S65 ME-C8	5-8		x	2xM10
L70 MC-C7	5-8		x	2xM10
L70 MC-C8	5-8		x	2xM10
L70 ME-C7	5-8		x	2xM10
L70 ME-C8	5-8		x	2xM10
S70 ME-C7	5-8		x	2xM10
S70 ME-C8	5-8		x	2xM10
S70 MC-C7	5-8		x	2xM10
S70 MC-C8	5-8		x	2xM10
S70 MC6	5-8	x		1xM12
K80 MC-C6	6-12	x		1xM12
S80 MC-C7	6-8		x	2xM10
S80 MC-C8	6-8		x	2xM10
K80 ME-C6	6-12	x		1xM12
K80 ME-C9	6-12		x	2xM12
S80 ME-C7	6-8		x	2xM10
S80 ME-C8	6-8		x	2xM10
S80 ME-C9	6-9		x	2xM10
S80 MC6	6-8	x		1xM12
S90 MC-C7	6-9		x	2xM10

**Installation, fixing and commissioning**

Engine type	Number of cylinders	Tube type bracket	Profile type bracket	Nord-Lock®
S90 MC-C8	6-9		x	2xM10
S90 ME-C7	6-9		x	2xM10
S90 ME-C8	6-9		x	2xM10
K90-ME-C6	6-12	x		1xM12
K90-ME-C9	6-12		x	2xM10
K90-MC-C6	6-12	x		1xM12
K90-ME9	6-12		x	2xM10
K98 MC-C6	6-12+14		x	2xM10
K98 MC-C7	6-12+14		x	2xM10
K98 ME-C6	6-12+14		x	2xM10
K98 ME-C7	6-12+14		x	2xM10
K98 ME6	6-12+14		x	2xM10
K98 MC6	6-12+14		x	2xM10
K98 MC7	6-12+14		x	2xM10
K98 ME7	6-12+14		x	2xM10
K108ME-C6	6-12+14		x	2xM10



Installation, fixing and commissioning

Mounting a tube type sensor bracket



NOTE!

The sensor brackets can only be mounted if all holes have been drilled into the web plate and threads (M10 or M12) have been inserted according to MAN Diesel drawings.

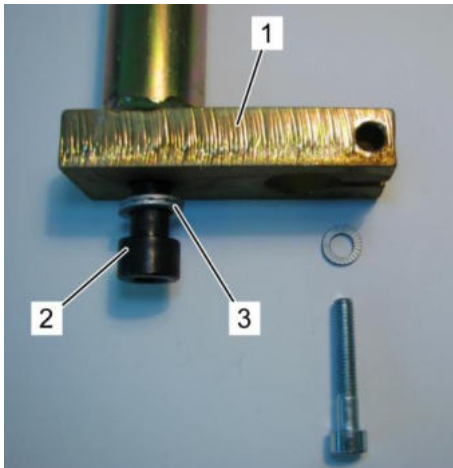

Fig. 28: Tube type sensor bracket

1. Attach two Nord-Lock® discs (Fig. 28/3) on the bolt M10 or M12 (Fig. 28/2).

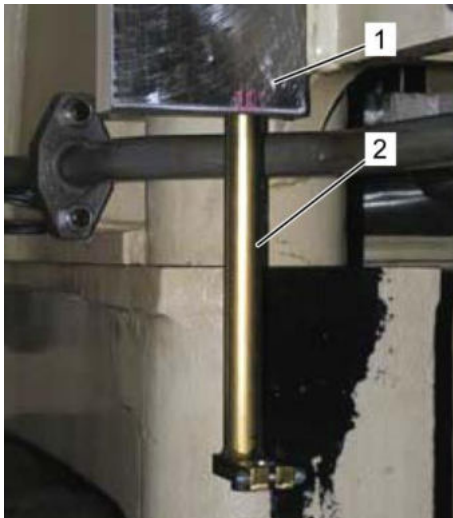

Fig. 29: Mounted tube type sensor bracket

2. Tighten the tube type sensor bracket (Fig. 29/2) with the bolt M10 or M12 (Fig. 29/1) in the web plate on left (first cylinder) or right (last cylinder) hand side of the crosshead.
 - M10: 70 Nm
 - M12: 120 Nm



NOTE!

Both Nord-Lock® discs are fitted with glue and must not be separated.
Do not use Loctite® or any other screw locking for mounting the tube type sensor brackets.

**Mounting a profile type sensor bracket****NOTE!**

The sensor brackets can only be mounted if all holes have been drilled into the web plate and threads (M10 or M12) have been inserted according to MAN Diesel drawings.

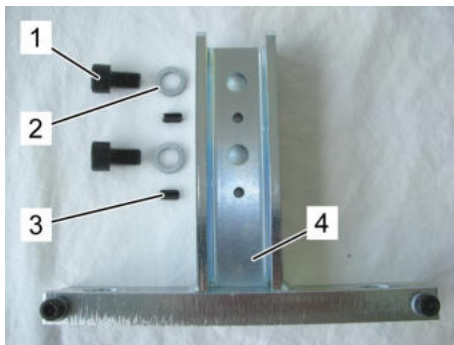

Fig. 30: Profile type sensor bracket

- 1 Bolt
- 2 Nord-Lock® disc
- 3 Alignment pin
- 4 Sensor bracket

1. Attach two Nord-Lock® discs (Fig. 30/2) on every bolt M8, M10 or M12 (Fig. 30/1).

**NOTE!**

Both Nord-Lock® discs are fitted with glue and must not be separated.
Do not use Loctite® or any other screw locking for mounting the tube type sensor brackets.

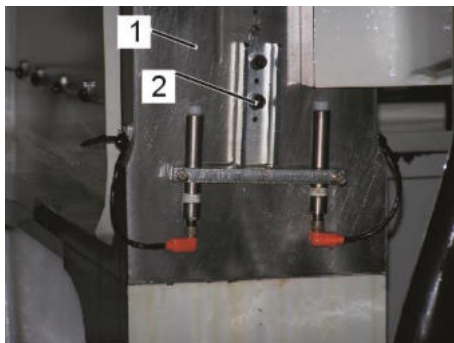

Fig. 31: Mounted double profile type sensor bracket

2. Tighten the profile type sensor bracket (Fig. 31/1) for two sensors with the bolts M8 or M10 (Fig. 31/2) centrally between the crosshead web plate.
 - M8: 35 Nm
 - M10: 50 Nm

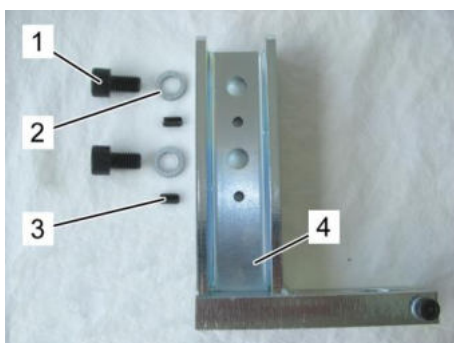

Fig. 32: Single profile type sensor bracket

- 1 Bolt
- 2 Nord-Lock® disc
- 3 Alignment pin
- 4 Sensor bracket

3. Tighten the profile type sensor bracket (Fig. 32/4) for one sensor (here bracket for cylinder no. 1 left hand side) with the bolts M8 or M10 (Fig. 32/1) and Nord-Lock® discs (Fig. 32/2) under the crossheads of the first and the last cylinder.
 - M8: 35 Nm
 - M10: 50 Nm



Installation, fixing and commissioning



NOTE!

See Appendix for installation schemas on how to mount sensor brackets in dependency of the number of cylinders.

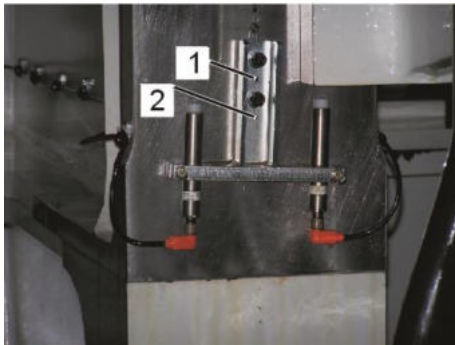

Fig. 33: Drillings for alignment pins

4. Drill two holes through the existing drill holes (Fig. 33/1+2) of each sensor bracket with a depth of 10 mm into the engine material by using the 5 mm drill.
5. Insert the alignment pins (Fig. 36) into these holes carefully by using the hammer.

6.3.3 Implementation of alignment pins.

For a higher accuracy, alignment pins are recommended.

Only after the sensor bracket is installed with 2 bolts (Fig. 37/1).

2 additional holes (Fig. 37/2) for the alignment pins can be drilled and the pins (Fig. 37/3) inserted.

The depth of the holes (Fig. 37/3) should not exceed 10 mm !

Please use an accurate 5 mm drill. Insert the alignment pins (Fig. 37/3).

Slightly insert the alignment pins into the holes by careful use of a hammer.

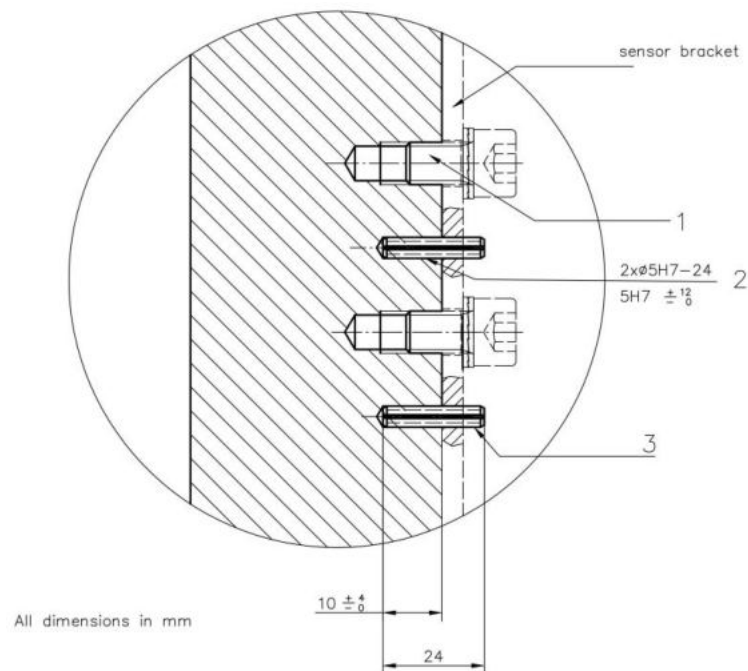



6.3.4 Mounting and adjusting the sensors

Matfunction

**CAUTION!**

Danger of malfunction through wrongly installed distance sensors!

The BDMS/BTMS will not work if sensors are installed incorrectly.

Therefore:

- Install distance sensor according the electrical connection diagram Fig.15
- Use the right connector for the respective sensor. As provided

**NOTE!**

The cylinder with the highest number is that one at the flywheel side. Opposite from the flywheel there is the cylinder with the lowest number. This is valid for MAN B&W engines; Wärtsilä / Sulzer engines have opposite counting therefore verify the sensor positions against the drawings valid for the specific engine!!

Example:

- Sensors 11 and 21 have to be mounted in the brackets of cylinder 1
- Sensors 12 and 22 have to be mounted in the brackets of cylinder 2 and so on

The respective number of a sensor is:

- written on its cap (Fig39/1)



Fig.39: Number written



Installation, fixing and commissioning

Mounting a sensor in a tube type sensor bracket into the engine

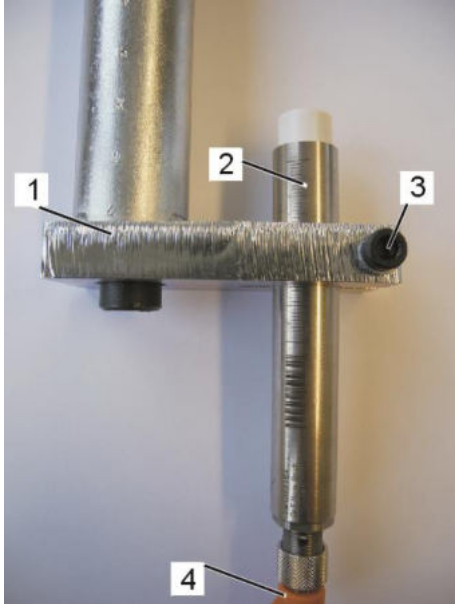

Fig.40: Sensor connected to bracket

1. Turn the engine so that the crosshead of the respective compartment is in the bottom dead center (⇒ see operating instructions of the engine manufacturer).
2. Connect the sensor cable (Fig.40/4) to the sensor to have a correct alignment of the connector.
 - Cable: KSG03248-15 for angle connectors
 - Cable: KSG03252-15 for straight connectors
3. Insert the sensor (Fig. 40/2) into the sensor bracket (Fig.40/1).
4. Clamp the sensor by lightly tightening the clamp screw (Fig.40/3).



NOTE!

Don't move the sensors forcibly by means of the connector! This can lead to destruction of the sensors!

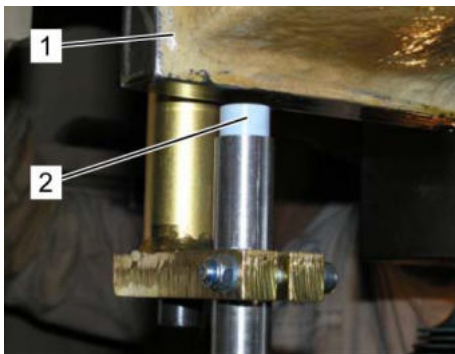

Fig. 34: Sensor mounted

5. Check if the crosshead (Fig. 41/1) is fully covering the sensor tip (Fig. 41/2).

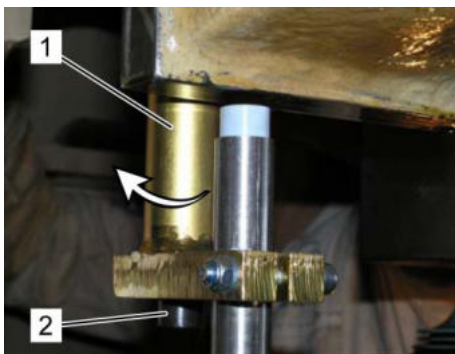

Fig. 35: Sensor under crosshead

6. If the crosshead is not fully covering the sensor tip loosen the bracket fixing bolt (Fig. 35/2) and then turn the bracket (Fig. 35/1), until the crosshead is fully covering the sensor tip (Fig. 35/arrow).
7. Then tighten the bracket fixing bolt (Fig. 35/2).



Installation, fixing and commissioning

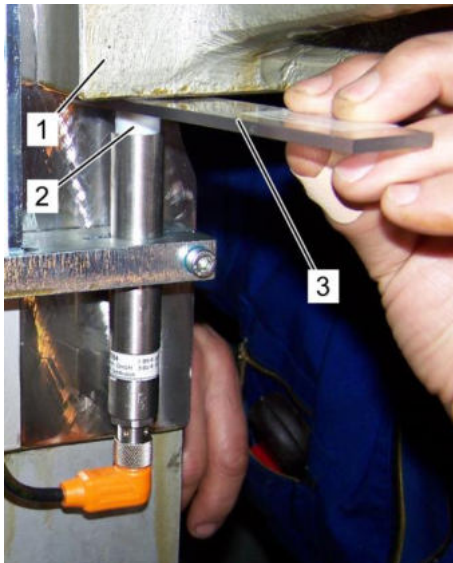

Fig. 36: Calibrating sensor

8. Insert the distance plate (Fig. 36/3) between crosshead (Fig. 36/1) and sensor tip (Fig. 36/2), to calibrate/adjust the distance



NOTE!

The illustrations in Fig. 36 and Fig. 37 show a profile type sensor bracket. The procedure is the same as for adjusting the tube type sensor brackets.

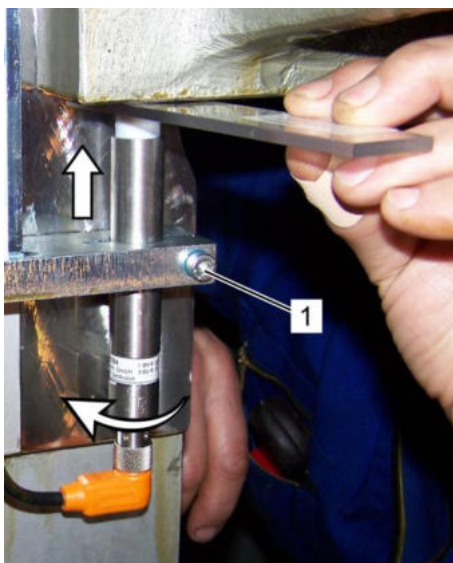

Fig. 37: Adjusting sensor

7. Push the sensor upward until it rests on the distance plate which has to be in contact with the lower part of the crosshead.
8. Turn the sensor in a way that the sensor cable connector shows in the foreseen way of cabling inside the engine. (this step is not necessary in case of straight connectors as shown in Fig. 43a)



NOTE!

Don't move the sensors forcibly by means of the connector! This can lead to destruction of the sensors!

9. Clamp the sensor by tightening the clamp screw (Fig. 37/1).
 - Torque moment: 16 Nm
 - **don't forget the Nord-Lock® discs to interlock the clamp screw**



Installation, fixing and commissioning



Fig. 38a: sensor with straight connectors



NOTE!

Repeat these steps with every sensor to be mounted.

Mounting a sensor in a profile type sensor bracket into the engine

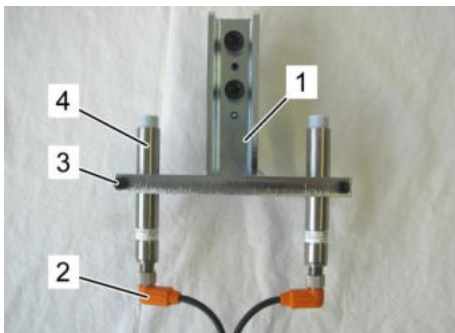

Fig. 39: Cables and sensor connected

1. Turn the engine so that the crosshead of the respective compartment is in the bottom dead centre (⇒ see operating instructions of the engine manufacturer).
2. Connect the sensor cable (Fig. 39/2) to the sensor at the respective compartment (the side where the crosshead is in the bottom dead centre) (Fig. 39/4) to have a correct alignment of the connector.
 - Cable: KSG03248-15 for angle connectors
 - Cable: KSG03252-15 for straight connectors



NOTE!

Don't move the sensors forcibly by means of the connector! This can lead to destruction of the sensors!

3. Insert the sensors in the sensor bracket (Fig. 39/1) at the respective compartment (the side where the crosshead is in the bottom dead centre)



Installation, fixing and commissioning



Fig. 40: Calibrating sensor

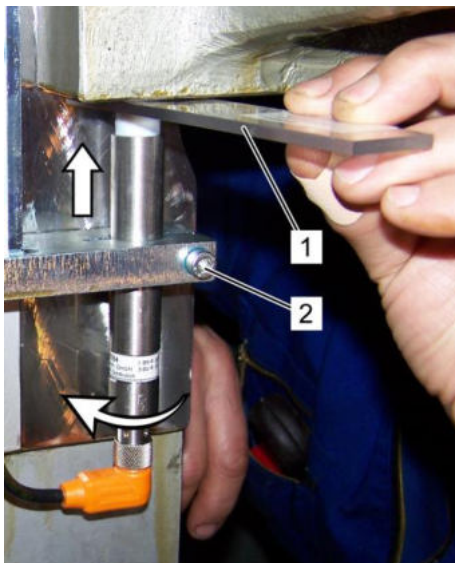

Fig. 41: Adjusting sensor



Fig. 42: Adjusting second sensor

4. Place the distance plate (Fig. 40/2) correctly under the surface of the crosshead in the bottom dead centre
5. Bear this sensor against the plastic sheet until it rests on the distance plate I (Fig. 41/1) which has to be in contact with the machined crosshead surface.
6. Turn the sensor in a way that the sensor cable connector shows towards the other sensor. (this step is not necessary in case of straight connectors as shown in Fig. 43a)



NOTE!

Don't move the sensors forcibly by means of the connector! This can lead to destruction of the sensors!

7. Tighten the respective clamp screw (Fig. 41/2) with 16 Nm.
 - **don't forget the Nord-Lock® discs to interlock the clamp screw**
8. Remove the calibration tool.
 - ↳ Between sensor and surface should be a gap of 4 mm.
9. Carry out the same procedure at the other sensors and adjust them in the same way to 4 mm gap between sensor and machined crosshead surface in the bottom dead centre (repeat steps 4 to 8).
10. Tighten the clamp screw with 16 Nm (Fig. 42/1).
 - **don't forget the Nord-Lock® discs to interlock the clamp screw!**



Installation, fixing and commissioning

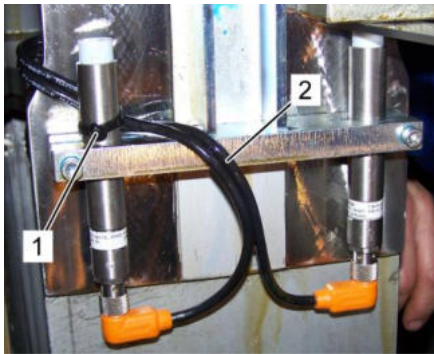

Fig. 43: Cable tie

11. Fix both cables (Fig. 43/2) with a cable tie (Fig. 43/1) and lead them towards the magnetic clips (grip magnets) or screwable fastening clamps.

- **Don't squeeze the cables with the cable ties in that way that the downsizing of the cross-section leads to any damage of the conductors inside the cables!**



NOTE!

Don't move the sensors forcibly by means of the connector! This can lead to destruction of the sensors!

Mounting a water-in-oil sensor

The water-in-oil sensor has to be installed into the pressure line previous to the engine (Fig. 44).

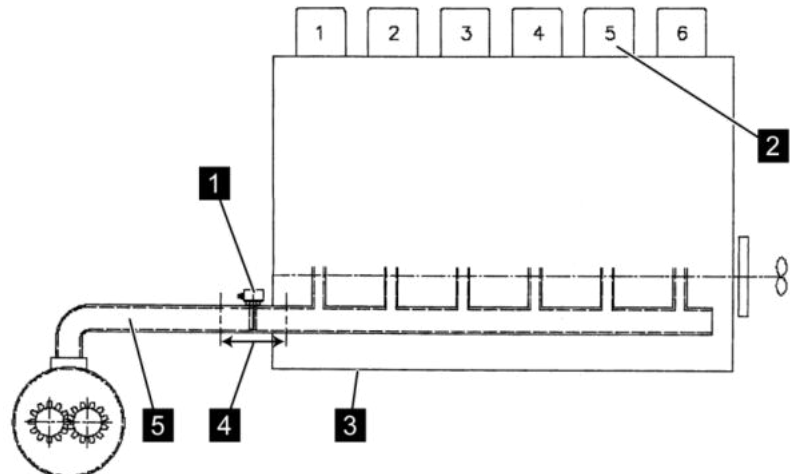

Fig. 44: Mounting area for the water-in-oil sensor

- 1 Water-in-oil sensor
- 2 Cylinder
- 3 Engine
- 4 Area where the water-in-oil sensor should be mounted
- 5 Pressure line



Installation, fixing and commissioning



WARNING!

Danger of injury caused by oil under pressure!

In case of defective lines or machine parts oil may escape under pressure. This can cause severe injuries.

Therefore:

- Do not open pipelines under pressure.
- Depressurize pipelines before starting any work.
- Have defective parts repaired.



Fig. 45: Mounting position

1. Choose an appropriate position (Fig. 45/1) in the pressure line for the sensor to be mounted.
2. Depressurize the oil pipe.
3. Remove a part of the pressure line according to Fig. 45.

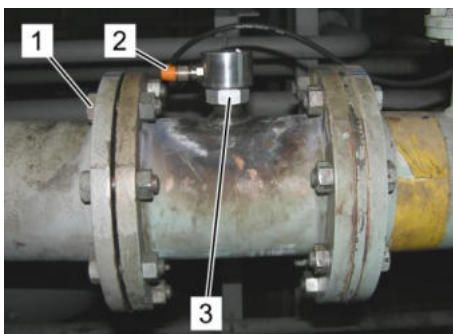

Fig. 46: Sensor mounted

1. Bolt
 2. Connector of sensor cable
 3. Water-in-oil sensor
4. Install the water-in-oil sensor according to Fig. 46.

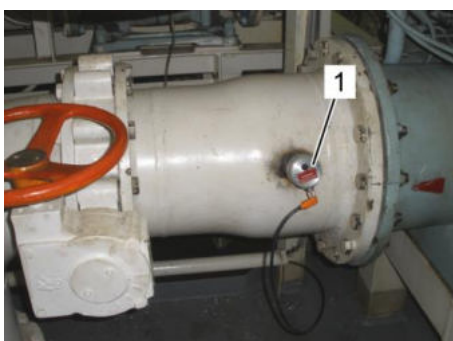

Fig. 47: Alternative mounting position

Fig. 47 shows an alternative mounting position of the water-in-oil sensor (Fig. 47/1).



Installation, fixing and commissioning

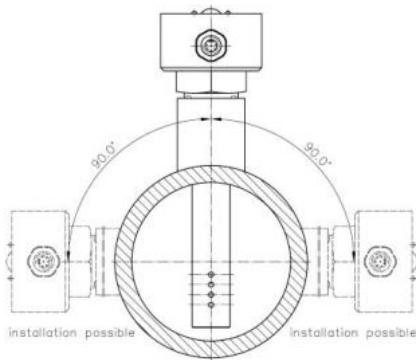

Fig.51: Positioning



NOTE!

We recommend mounting the sensor in a position range of 90°.

6.3.5 Placing and fixing of cables inside the engine



CAUTION!

Damage to cables caused by improper laying!

Cables might get damaged if they are laid improperly.

Therefore:

- Follow the instructions in this Manual corresponding to the placement of cables.
- Avoid placing cables around sharp corners.
- Make sure cables are not buckled.
- Lead cables only through the respective cable glands.



6.3.5.1 Placing and fixing of cables inside new engines under construction

Cables of the sensors inside the engine have to be placed according to the following instruction and drawings.

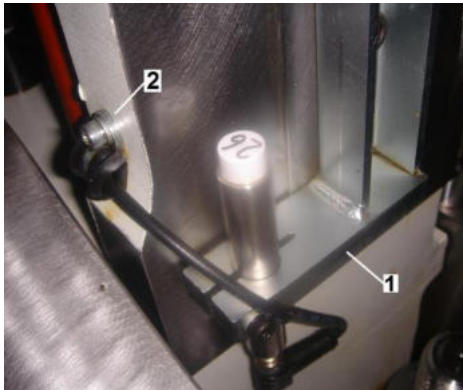

Fig. 48: Cables through fastening clamp

1. Lead the cables from the sensor bracket (Fig. 48/1) through the fastening clamp (Fig. 48/2) on the bed plate (if necessary).



NOTE!

Start the cabling from the inside out (from the sensor to the cable glands out of the engines) to avoid the form of the cable loops inside the engine!



NOTE!

Don't move the sensors forcibly by means of the connector! This can lead to destruction of the sensors!

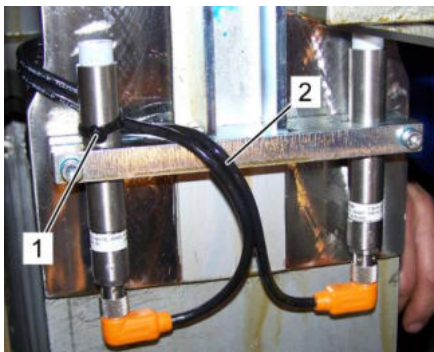

Fig. 49: Cable tie

2. Fix cables by cable ties wherever possible according to the picture Fig 53: Cable tie



NOTE!

Don't squeeze the cables with the cable ties in that way that the downsizing of the cross-section leads to any damage of the conductors inside the cables!

For new buildings the cables inside the engine are guided by magnetic clips (grip magnets) or srewable fastening clamps



The engine manufacturers MAN as well as WÄRTSILÄ prefer the method of cable installation in the engine with magnetic clips. This method saves the drilling in the engines and prevents consequently an attenuation of the engine frame. Dr. E. Horn GmbH strongly recommends to use magnetic clips for cable installation within the engines.



Installation, fixing and commissioning

cable installation inside the engine by means of magnetic clips

Fig.58: Schematic for placing the magnetic clips inside the engine

1 Sensor Cable

4 Loctite®

5 Magnetic clip sufficient for 1...3 sensor cables

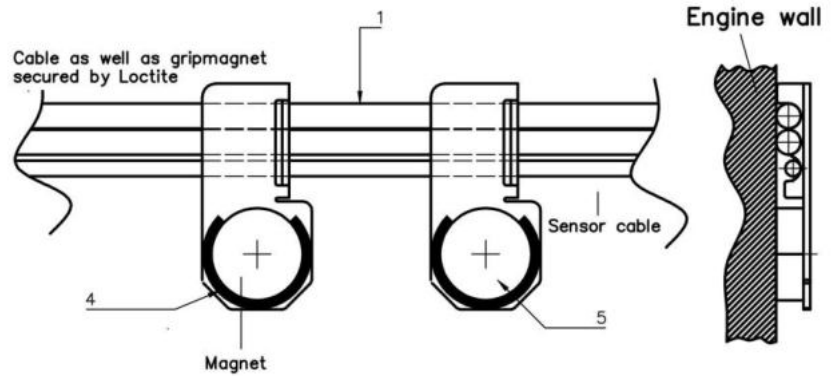

How to fix the magnetic clips:

- The surface should be as smooth as possible
- Clean the foreseen area of the bedplate with a suitable cleaner (acetone or similar)
- The surface must be 100% free of oil, grease, lubricant
- The surface of the magnet must 100% rest on the bedplate surface and also free of oil, grease etc.
- Lead cables without twisting from one to the next magnetic clip
- The distance between the magnetic clips should be between 30... 50 cm
- Before and after a corner use one magnet clip each
- Secure the magnets against slipping by the provided glue (part of the delivery)
- Apply the glue around the magnet according the above drawing

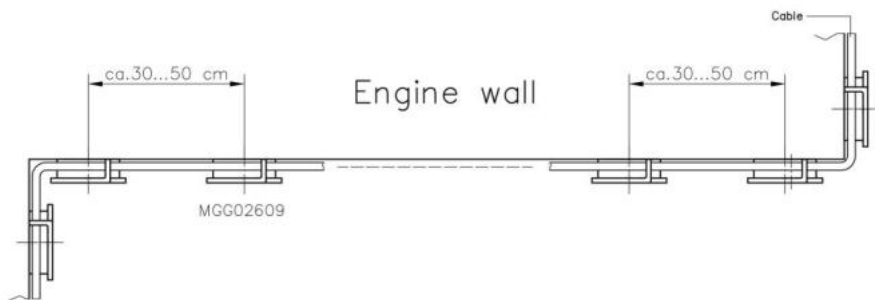

NOTE!

There must be under no circumstances glue between the magnet surface and the bedplate surface! The glue is to secure the magnet clips against slipping while engine vibration.



Installation, fixing and commissioning

cable installation inside the engine by means of screwable holder

1 Cable

6 Screwable cable holder

- Sufficient for 1 – 3 cables

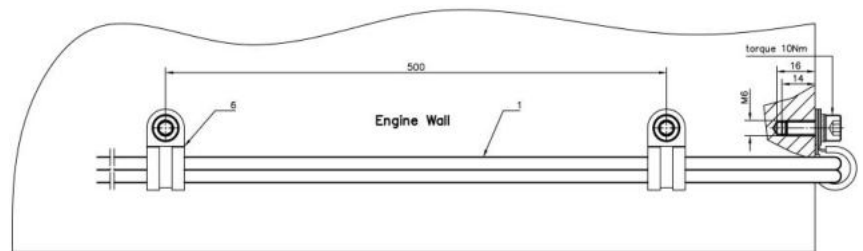

Fig.54: Schematic for placing the screwable holder inside the engine



NOTE!

Start the cabling from the inside out (from the sensor to the cable glands out of the engines) to avoid the form of the cable loops inside the engine!

How to fix the screwable cable holder:

- Lead the cables from sensors to the cable glands out of the engine to avoid the form of any cable loops inside the engine
- Lead cables without twisting from one to the next cable holder
- The distance between the cable holders should be approx. 500 mm
- Before and after a corner use one cable holder each

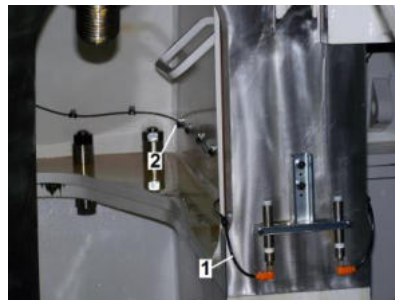

Fig55: application of screwable cable holder in the engine

1 Cable

2 Screwable cable holder



Installation, fixing and commissioning

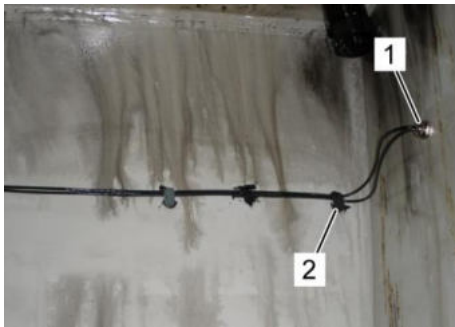

Fig. 56: Cable gland inside the engine

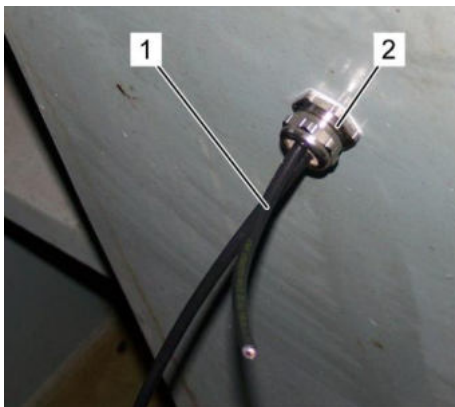

Fig.57: Cable gland outside the engine

4. Lead cables (Fig. 56/2) through cable glands (Fig. 56/1) from the inside (Fig. 56) to the outside (Fig.57) of the engine.
2. Tighten the cable glands inside the engine.
1 cable gland inside the engine
2 cables inside the engine
3. Tighten the cable glands outside the engine after all sensors have been mounted.
1 cables outside the engine
2 cable gland outside the engine



NOTE!

The number of cables that have to be led through the cable glands depends on the type of engine and whether there is a main bearing temperature sensor installed or not.

6.3.5.2 Placing and fixing of cables for retrofit installation



NOTE!

*The cables of the sensors inside the engine have to be placed according to the same instructions and drawings as for new engines under construction (chapter 6.3.4.1) . **Both, the installation with magnetic clips (grip magnets) and with screwable cable holder can be used.** However, the **preferred method should be the installation by means of the magnetic clips** to avoid unnecessary drilling (metal cuttings) in the engine compartment.*



6.3.6 Mounting BLG00402 and BLG00403

**CAUTION!**

Please make sure that the BLG00402 or BLG00403 are mounted about 1m higher than the engine A-frame.

**NOTE!**

One Terminal box can take up to 17 sensors max. In case of a BDMS/BTMS with a 7-cylinder engine 14 distance sensors and one water-in-oil sensor can be connected to one Terminal box.(BLG00402)

If more than 17 sensors should be installed (8 cylinders or more) a second Terminal box is needed.(BLG00403)

The following table provides an overview taking into account the number of cylinders of the engine, the respective number of installed distance sensors and the required quantity of Terminal boxes.

Cylinders	Distance sensors	Terminal boxes
4-7	8-14	1 (BLG00402)
8-14	15-28	2 (BLG00403)

The respective schematic drawings are enclosed in the Appendix, chapter 10.3.



Fig.58: Mounting bracket BLG00402 with terminal box GHG002621... and one line converter box GHG002611...

**NOTE!**

The Terminal box(es) should be mounted near the cable glands on the manoeuvre side of the engine.

1. Mounting plate BLG00402 for one Terminal box GHG02621-3, or BLG00403 for two Terminal boxes GHG02621-3.
Fig.59 and Fig.60
2. The mounting plate have to be mounted outside of the engine bedplate on its surface.
Take into account the length of the cables which have to be connected to the Terminal box when selecting a place for mounting:
 - Distance sensor cables: 15 m
 - Water-in-oil sensor cables: 15 m
3. Remove possible colour on the engine block to guarantee a metallic bright surface for assembling the GND strap.
4. Screw the GND strap with a 6 mm hexagonal bolt onto the engine block.
 - M6: 6 Nm



Installation, fixing and commissioning

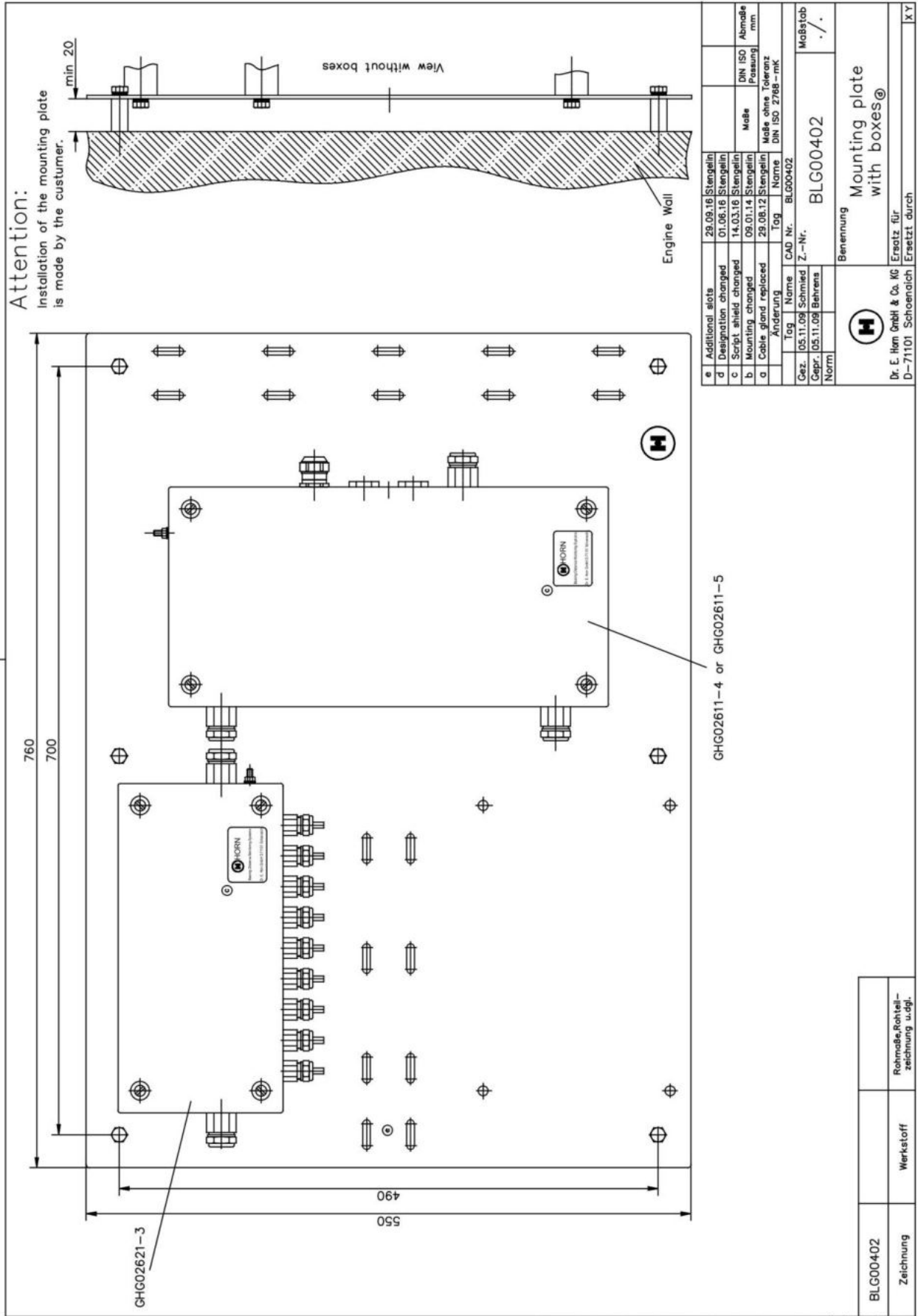

All rights reserved. Document may not be reproduced or disclosed to a third party or used for any other purpose without our written consent - Protection notice ISO 15076 is valid.



Installation, fixing and commissioning

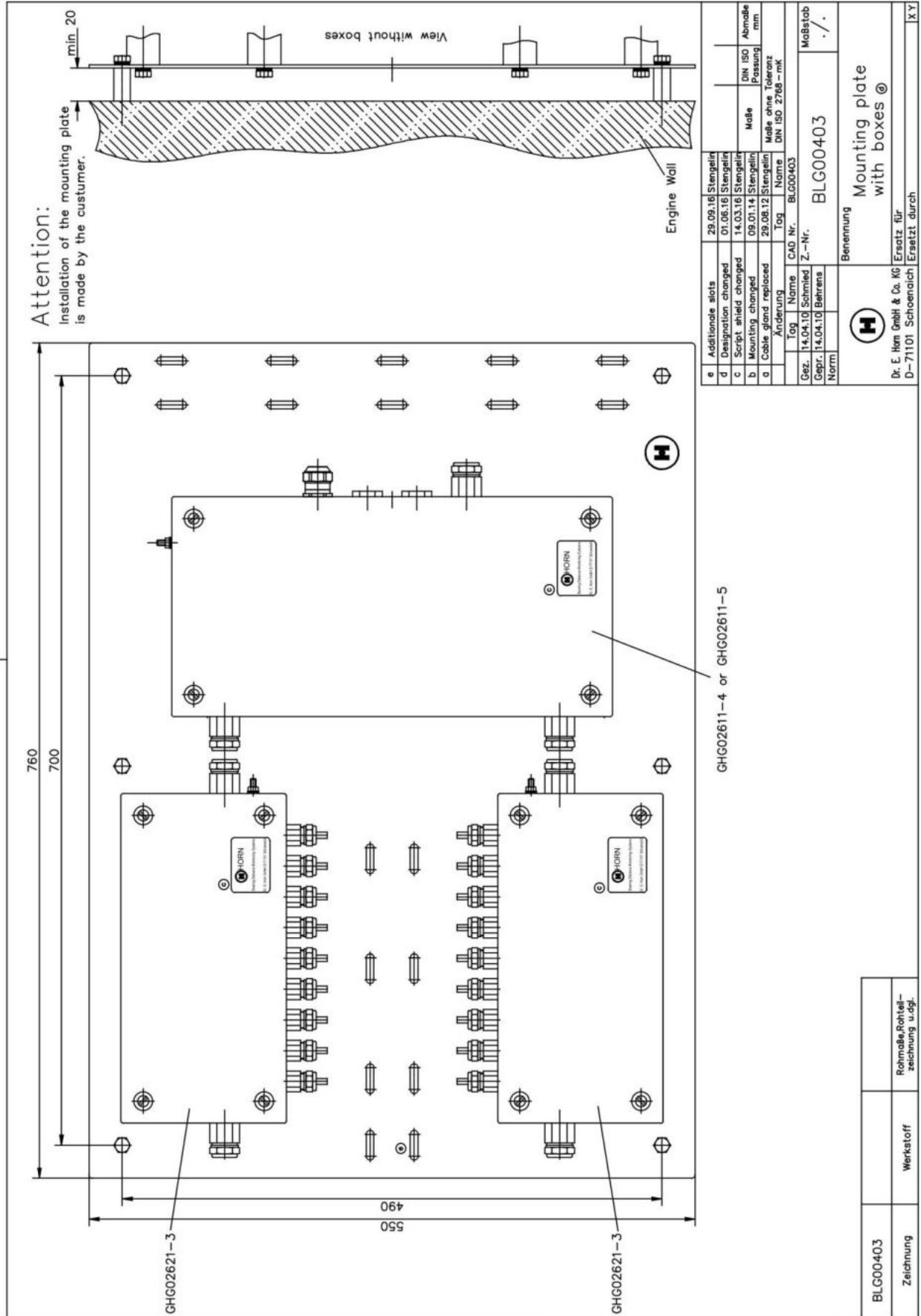

Fig.60:BLG00403

All rights reserved. Document may not be reproduced or disclosed to a third party or used for any other purpose without our written consent - Protection notice ISO 16016 is valid.



Installation, fixing and commissioning

6.3.7 Mounting Terminal and Line Converter box without BLG0040....

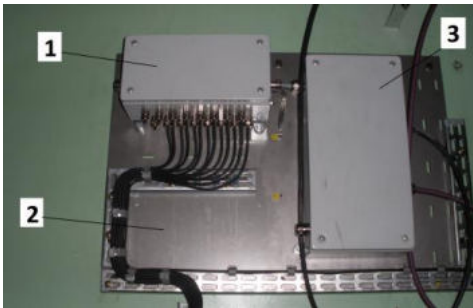

Terminal boxes (GHG02621-3 Fig.61/1) and line converter box (GHG2611-.. Fig.61/3) are fixed on a mounting plate (BLG00402 Fig.61/2,BLG00403),which is fixed one engine side.

Fig. 61: Connection box

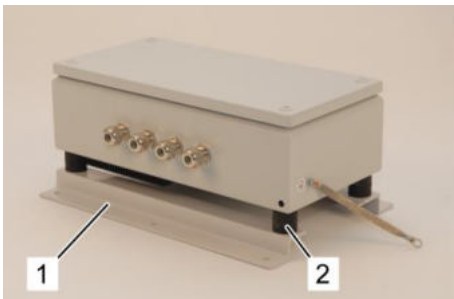

Optional each box can be fixed directly at engine side, using a fixing rail (Z-profile Fig.62/1) without mounting plate.

Fig. 62: Z-profile

6.3.8 Connecting the Terminal box

- Make sure the Terminal box is mounted correctly.



Installation, fixing and commissioning



CAUTION!

Damage to cables in case of improper leading!

The cables of the sensors might get damaged if they are not led through the cable trays.

Therefore:

- Always use the provided cable trays to lead cables.
- Mount additional cable trays if necessary.

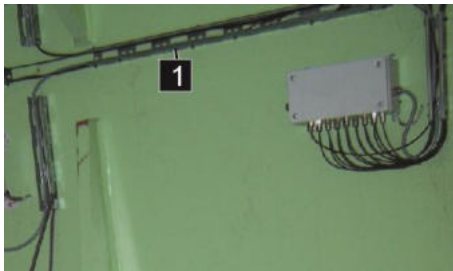

Fig.65: Cable trays on engine block

1. Lay cables of all sensors that have to be attached through cable trays (Fig.65/1) to the Terminal box.



NOTE!

Cables that are too long may be shortened or coiled up and fastened on the cable tray or Terminal box.

Leading cables into the box

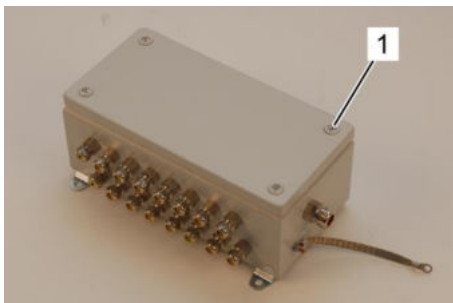

Fig.66: Screws on the Terminal box

2. Prepare all cables according to the description
3. Loosen the screws on the Terminal box (Fig.66/1) and open it.

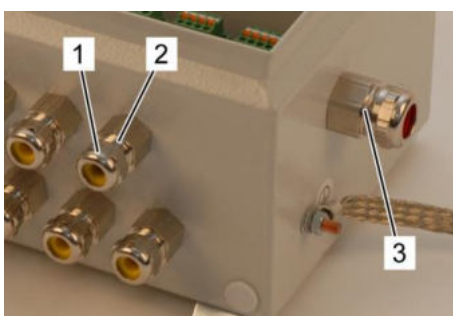

Fig.67: Types of cable glands

4. Loosen the pressure screw of the cable glands (Fig.67/1).
5. Guide the cables from the sensors through the smaller cable glands (Fig.67/2) into the Terminal box.
6. Guide the bus cables (LT2004F0) through the bigger cable glands on the side (Fig.67/3) into the Terminal box.



Installation, fixing and commissioning

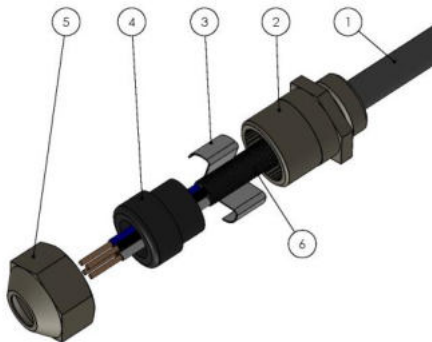

Fig.68: Spring on naked screen

7. Make sure all cables (Fig.68/1) are placed correctly and the spring (Fig./3) is in contact with the naked screen (Fig.68/6).

8. Connect the conductors to the respective connector according to chapters 6.3.8.1 to 6.3.8.2.
9. Close the Terminal box and tighten the screws.

6.3.8.1 Connecting sensors



NOTE!

Inside the Terminal box the distance sensors can be connected to any available connector without following a routine.

Distance sensors, water-in-oil sensor and main bearing temperature sensor get connected similarly.

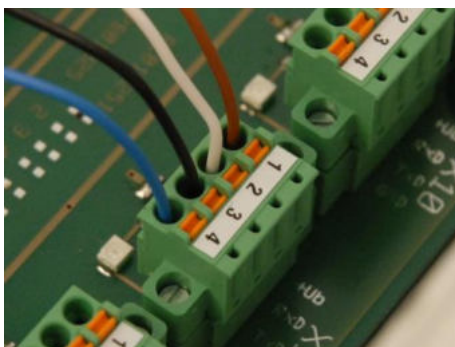

Fig. 50: Connecting a sensor

1. Connect the conductors of the sensors according to Fig. 50. For details refer to the respective terminal diagrams.

Slot	Marking	Conductor colour
1	+u _b	brown
2	RxD	white
3	TxD	black
4	GND	blue



6.3.8.2 Connecting the bus cable



Fig. 51: Connectors for bus cable



Fig. 52: Connecting the bus cable

The Terminal box has two connectors for a bus cable. They are identified as X20 (Fig. 51/1) and X19 (Fig. 51/2).

1. Choose a connector taking into account the position of the Line Converter box.
 - X19: To Line Converter box (GHG02611-..) X3 or X4 or Terminal box (GHG02621-3) X20
 - X20: From Terminal box (GHG02621-3) X19

2. Connect the conductors of the bus cable according to Fig. 52. For details refer to the respective terminal diagrams.

Slot	Marking	Conductor colour
1	+u _b	green
2	RxD	brown
3	TxD	yellow
4	GND	white



Installation, fixing and commissioning

6.3.9 Connecting the Line Converter box

- Make sure the Line Converter box is mounted correctly.



CAUTION!

Damage to cables in case of improper leading!

The cables might get damaged if they are not led through the cable trays.

Therefore:

- Always use the provided cable trays to lead cables.
- Mount additional cable trays if necessary.

There are two types of Line Converter boxes available:

- GHG02611-4 for 24 V DC
- GHG02611-5 for 115-230 V AC

These types have different ship voltage supply connections for AC and DC types.

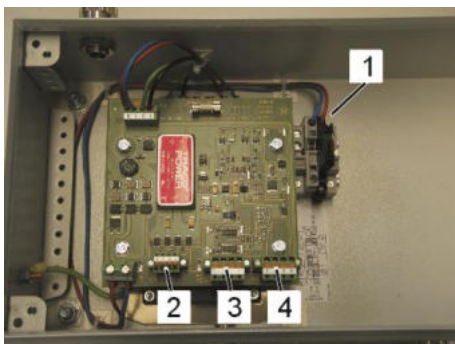

Fig.72: Connectors

The Line Converter box has four connectors:

- X1: Power supply for the board Fig.(72/1)
- X2: Always connected by the manufacturer: Bus cable to indication unit (Fig.72/2)
- X3: Always connected by the manufacturer: Bus cable from Terminal box on the left of the Line Converter box (Fig.72/3)
- X4: Bus cable from Terminal box on the right of the Line Converter box (Fig.72/4)

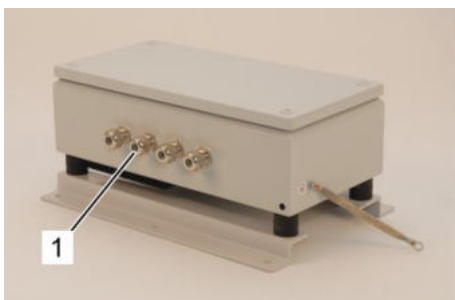

Fig.73: Cable glands

The Line Converter box has four cable glands, one for each cable (Fig.3/1). The bus cables from the Terminal boxes are thinner than the others. So they have to be led through both the right cable glands.



NOTE!

If only one Terminal box is installed it has to be connected to connector X3.



Installation, fixing and commissioning

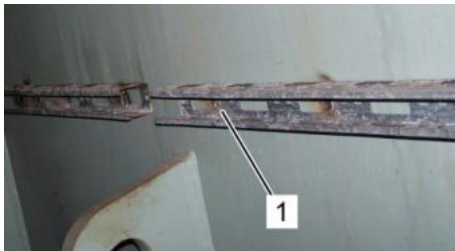

Fig.74: Cable trays on engine block

1. Lay cables through cable trays (Fig.74/1) to the Line Converter box.



NOTE!

Cables that are too long may be shortened or coiled up and fastened on the cable tray or Line Converter box.

Leading cables into the box



Fig. 75: Screws on the Line Converter box

2. Prepare all cables according to the description in "Preface".
3. Loosen the screws on the Line Converter box (Fig.75/1) and open it.

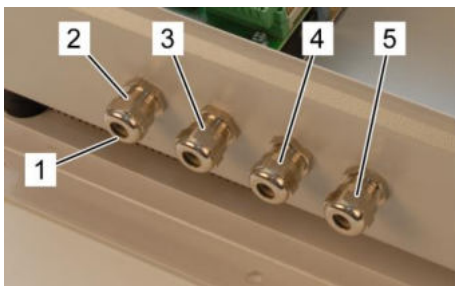

Fig. 76: Types of cable glands

4. Loosen the pressure screw of the cable glands (Fig.76/1).
5. Always connected by the manufacturer: Guide the bus cables from the Terminal boxes through both the cable glands in the middle (Fig.76/3+4) into the Line Converter box.
6. Guide the bus cable to the Indication unit (LT2004D0) through the cable gland on the left (Fig.76/2) and the power supply through the cable gland on the right (Fig.76/5) into the Line Converter box.

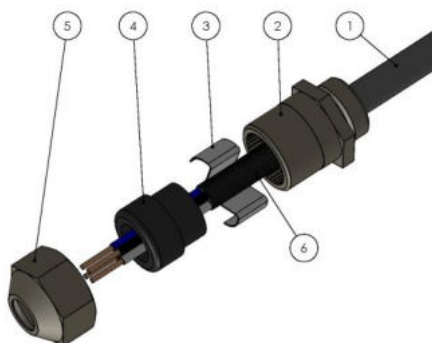

Fig. 78: Spring on naked screen

7. Make sure all cables (Fig.78/1) are placed correctly and the spring (FIG.78/3) is in full contact with the naked screen (Fig.78/6).
8. Tighten the pressure screw (Fig.78/1) of each cable gland so that the cable is fixed.
9. Connect the conductors to the respective connector according to chapters 6.3.9.1 till 6.3.9.3.
10. Close the Line Converter box and tighten the screws.



Installation, fixing and commissioning

6.3.9.1 Connecting the bus cables from the Terminal boxes

- Type of cable: LT2004F0

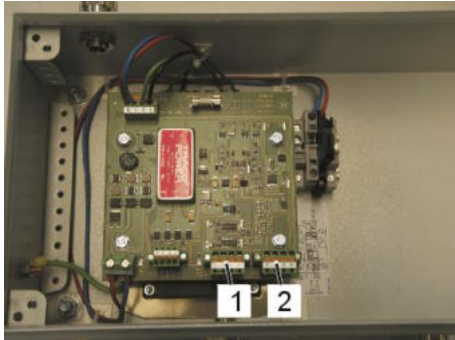

Fig.79: Connectors X3 and X4

The bus cables of the Terminal boxes have to be connected to the connectors X3 and X4.

- 1 Connector X3
- 2 Connector X4

- Bus cable from Terminal box on the left to X3 (Fig.79/1)
- Bus cable from Terminal box on the right to X4 (Fig.79/2)

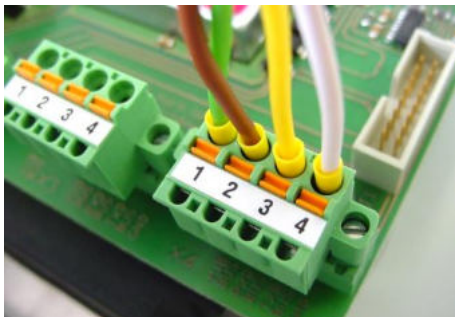

Fig.80: Connecting the bus cables

1. Connect the conductors of the bus cables according to Fig.80. For details refer to the respective terminal diagrams.

Slot	Marking	Conductor colour
1	+u _b	green
2	RxD	brown
3	TxD	yellow
4	GND	white

6.3.9.2 Connecting to the ship's/plant's power supply

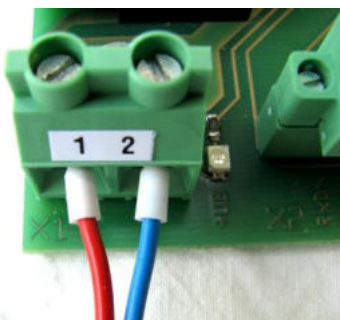

Fig. 81: Board power supply

All cabling inside the Line Converter Box except the bus connections at X2, X3 and X4 are factory-made.

So the board power supply at X1 looks as shown in Fig.81.

Position	Marking	Conductor colour
1	+24 V	red
2	0 V	blue



Installation, fixing and commissioning

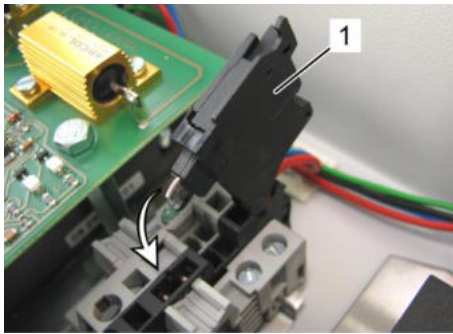

Fig. 82: Power switch

The centralized power supply from the ship is carried out via the power switch (Fig. 82/1). It can be closed to switch on and opened to switch off the power supply from the ship.

Connecting to Line Converter box type GHG02611-4

- 24 V DC from ship net

1. Connect the conductors of the power supply according to Fig. 83. For details refer to the respective terminal diagrams.
2. Use the screws to tighten the conductors.

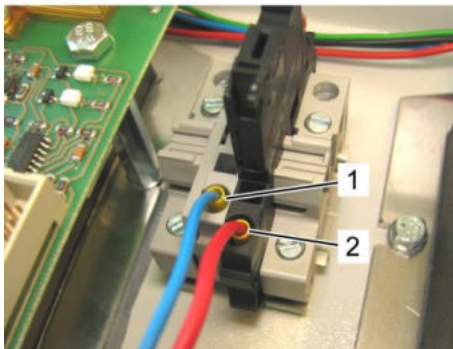

Fig. 83: Connection with 24 V DC

Position	Marking	Conductor colour
1	–	blue
2	+	red

Connecting to Line Converter box type GHG02611-5

- 115/230 V AC from ship net

1. Connect the conductors of the power supply according to Fig. 84. For details refer to the respective terminal diagrams.
2. Use the screws to tighten the conductors.

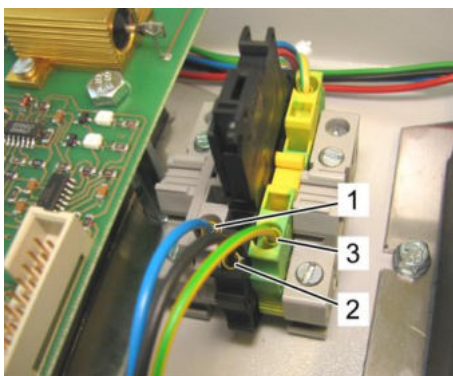

Fig. 84: Connection with 115/230 V AC

Position	Marking	Conductor colour
1	–	blue
2	+	black
3	GND	yellow/green



Installation, fixing and commissioning

6.3.9.3 Connecting the bus cable of the Indication unit

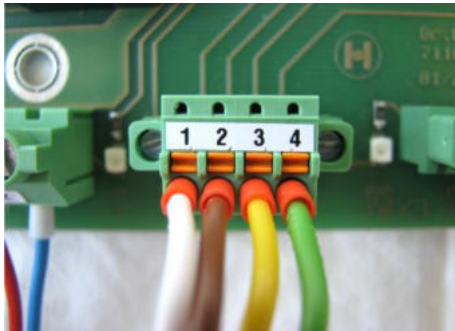

Fig. 85: Connecting the bus cable

- Type of cable: LT2004D0

1. Connect the conductors of the bus cable according to Fig.85. For details refer to the respective terminal diagrams.

Slot	Marking	Conductor colour
1	RxD\	white
2	RxD	brown
3	TxD\	yellow
4	TxD	green

6.3.10 Mounting the Indication unit

The Indication unit can be installed in two different ways:

- Inside of the optionally available field housing inside the engine room (MDA312... in field housing GHG02631)
- Into a switchboard or control console panel in the control room of the ship (MDA312...)



NOTE!

The indication unit may be theoretically mounted in a distance up to 1000 m to the Line Converter box. However, please consider the agreed cable length.

Mounting inside the engine room

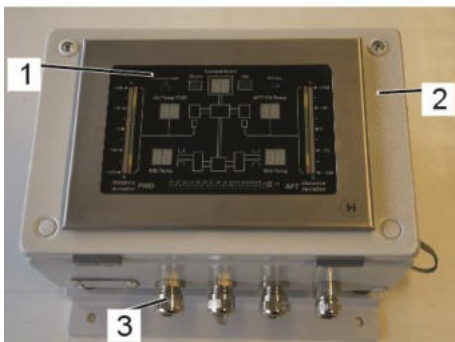
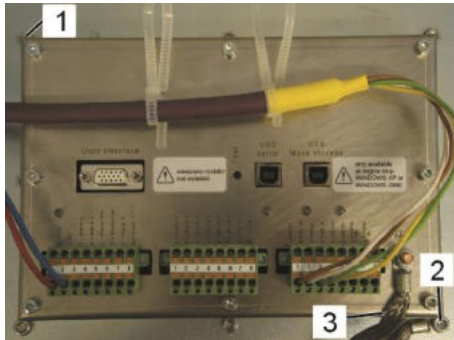

Fig.86: Indication unit with cable glands

1. Connect the Indication unit (Fig.86/1) to the housing (Fig.86/2).
2. Attach the Indication unit to the bulkhead either by bolts or by electrical welding. The cable glands (Fig.86/3) have to be on the bottom side of the box.
 - Bolts and Nord-Lock® discs are included in delivery.
3. Remove possible colour on the engine block to guarantee a metallic bright surface for assembling the GND strap.
4. Screw the GND strap onto the bulkhead.

**Mounting inside the control room***Fig. 87: Indication unit in control room*

1. Fix the Indication unit on the control panel in a suitable position with screws on its back (Fig87/1).
2. Remove possible colour on the back of the control panel to guarantee a metallic bright surface for assembling the GND strap (Fig.87/2).
3. Screw the GND strap (Fig87/3) onto the back of the control panel.

6.3.11 Connecting the Indication unit

- Make sure the Indication unit is mounted correctly.

**CAUTION!****Damage to cables in case of improper leading!**

The cables might get damaged if they are not led through the cable trays.

Therefore:

- Always use the provided cable trays to lead cables.
- Mount additional cable trays if necessary.

The connecting has to be made via the cable glands or directly to the connectors depending on the type of Indication unit.

- MDA312...: Connecting through cable glands
- MDA312...: Direct connection to connectors

The Indication unit has among others three connectors:

- X11: Power supply and alarm contacts (Fig87/1)
- X12: Alarm contacts (Fig. /2)
- X13: Bus cable from Line Converter box (Fig87/3)

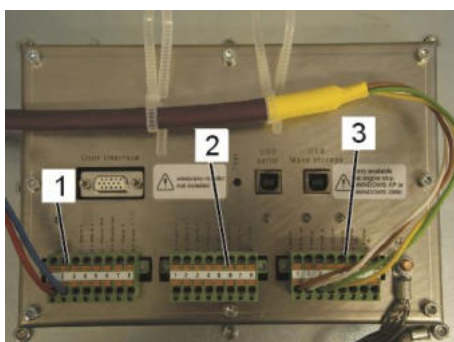
*Fig. 87: Connectors*



Installation, fixing and commissioning

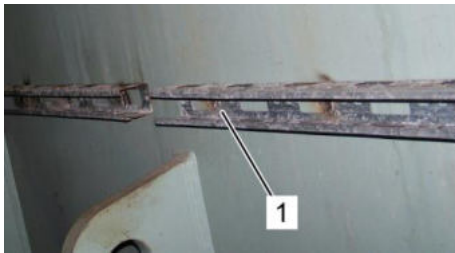

Fig. 88: Cable trays on engine block

1. Lay cables through cable trays (Fig.88/1) to the Indication unit.



NOTE!

Cables that are too long may be shortened or coiled up and fastened on the cable tray or the Indication unit.

The violet cable from the Line Converter Box has to be laid on the best way in the vessel on existing cable rails.

Avoid parallel running with power cables and too close distances to generator sets.

Leading cables into Indication unit MDA312...

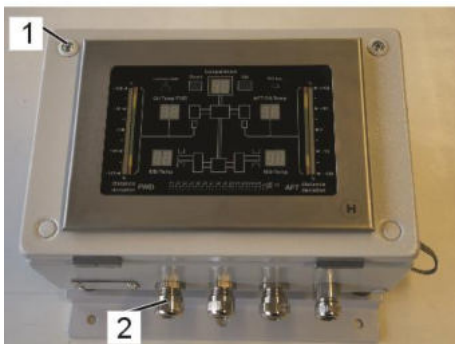

Fig.89: Indication unit

When using the Indication unit type MDA 312... it is necessary to lead the cables into the unit via cable glands.

2. Prepare all cables according to the description in "Preface".
3. Loosen the screws on the Indication unit (Fig.89/1) and open it.
4. Loosen the pressure screw of the cable glands.
5. Guide the cables through the cables glands (Fig.89/2) into the Indication unit.

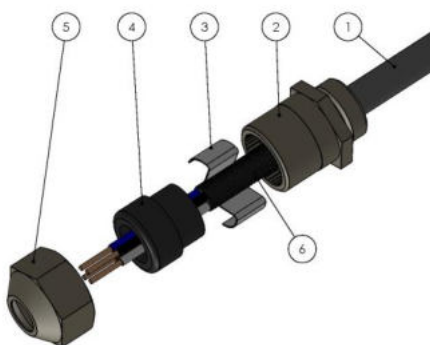
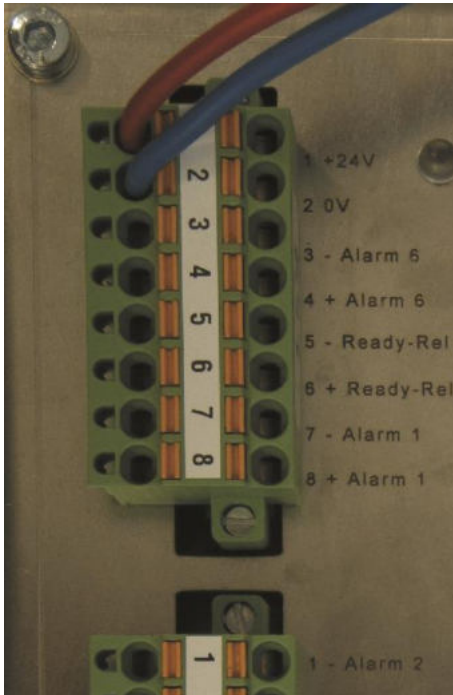

Fig. 90: Spring on naked screen

6. Make sure all cables (Fig90/1) are placed correctly and the spring (Fig.90/3) is in contact with the naked screen (Fig.90/6).
7. Connect the conductors to the respective connector according to chapters 6.3.11.1 to 6.3.11.2.
8. Close the Indication unit and tighten the screws (Fig.90/1).



6.3.11.1 Connecting the power supply



The power supply is connected to the connector X11 (Fig. /1).

1. Connect the conductors of the power supply according to Fig.91. For details refer to the respective terminal diagrams.

Slot	Marking	Conductor colour
1	+24 V	depends on yard connection
2	0 V	depends on yard connection

Fig. 91: Connecting power supply



Installation, fixing and commissioning

6.3.11.2 Connecting the bus cable from the Line Converter box

- Type of cable: LT2004D0

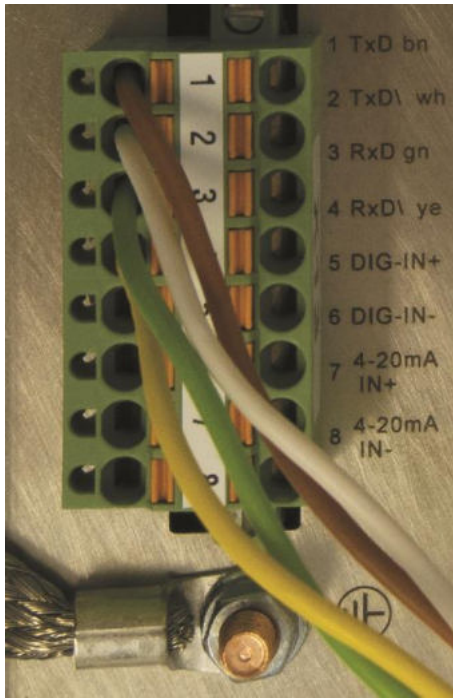

1. Connect the conductors of the bus cable according to Fig.92. For details refer to the respective terminal diagrams.

Slot	Marking	Conductor colour
1	TxD	brown
2	TxD\	white
3	RxD	green
4	RxD\	yellow

Fig.92: Connecting bus cable

**6.3.11.3 Connecting the engine alarm and engine safety system**

The Indication unit delivers the alarm contacts potentially free.

Connect the respective conductors according to the following table and Fig.93.

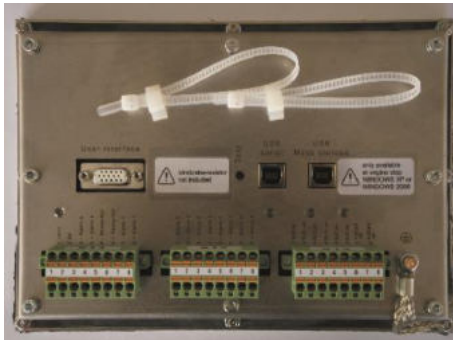

Fig. 93: View about the connectors

Slot	Marking	Connection
X11/3	– Alarm 6	– Relay 6/H ₂ O main-alarm**/N. O.
X11/4	+ Alarm 6	+ Relay 6/H ₂ O main-alarm**/N. O.
X11/5	– Ready-Rel	– Ready Relay*/N. C.
X11/6	+ Ready-Rel	+ Ready Relay*/N. C.
X11/7	– Alarm 1	– Relay 1/bearing wear alarm*/N. O.
X11/8	+ Alarm 1	+ Relay 1/bearing wear alarm*/N. O.
X12/1	– Alarm 2	– Relay 2/bearing wear slow down**/N. O.
X12/2	+ Alarm 2	+ Relay 2/bearing wear slow down**/N. O.
X12/3	– Alarm 3	– Relay 3/Main bearing temperature alarm*/N. O.
X12/4	+ Alarm 3	+ Relay 3/Main bearing temperature alarm*/N. O.
X12/5	– Alarm 4	– Relay 4/ Main bearing temperature slow down **/N. O.
X12/6	+ Alarm 4	+ Relay 4/ Main bearing temperature slow down **/N. O.
X12/7	– Alarm 5	– Relay 5/ H ₂ O pre-alarm */N. O.
X12/8	+ Alarm 5	+ Relay 5/ H ₂ O pre-alarm */N. O.

• connection to engine alarm system

** connection to engine safety system

**NOTE!**

Wirebreak resistors to be mounted in parallel with relay contacts at X11, X12 according to suppliers requirements for alarm and safety system.



Installation, fixing and commissioning

6.3.11.4 Other connectors

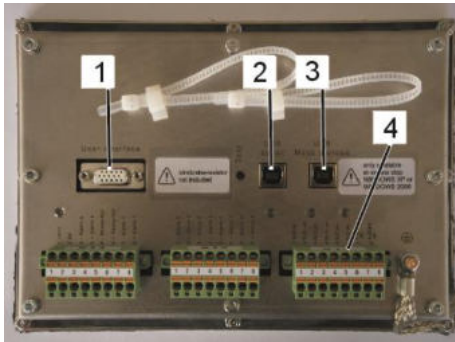

Fig.94: View about the connectors

1. User – Interface

special service connector for temporary connecting the handheld terminal.

2. USB Serial

USB-interface for connection of any PC (PC not included in scope of supply)

At connection the WINDOWS-device manager creates a COM-port. Please insert 115200 bps/8/N/1

real time output of sensor measuring data.

reception is possible with software like hyper-terminal direct from the WINDOWS operating system or with software LagMon from Dr. E. Horn

3. USB Mass Storage

USB-interface for connection of any PC (PC not included in scope of supply)

access to the internal memory card with WINDOWS-EXPLORER. It is possible to record the data of the memory card at any PC (PC not included in scope of supply)



NOTE!

Access to the internal memory card only at engine standstill!

4. X 13 pin 5 ... 8

X13-5 - 24 VDC for binary contactor “Diesel engine rotation backwards” (maneuvering)

X13-6 - binary input for “backwards-signal” from contactor or 24 V-logic

X13-7 - analogue input 4 – 20 mA (+) for engine load signal

X13-8 - analogue input 4 – 20 mA (-) for engine load signal



6.4 Checks

**CAUTION!**

Make sure that all cable glands and Cover lid are tightly closed before engine and commissioning started.

There are a few checks that have to be carried out before commissioning.

Checking connections

- Make sure that all sensors are connected correctly inside the engine in line with the ID numbers for 4 to 14 cylinder engines mentioned in the Annex.
- Recheck all power connections between Terminal box(es) and Line Converter box for correct connection. Obey the colour code.
- Recheck the bus connections between Terminal box(es) and Line Converter box for correct connection. Obey the colour code.
- Recheck the bus connections between Line Converter box and Indication unit in the engine control room for correct connection. Obey the colour code.
- Check if all GND connections at Terminal box(es), Line Converter box and Indication unit are mounted with the copper mash bands to the units.
- Measure the voltage foreseen to be used to make sure that 24 V DC are not mixed up with 115/230 V AC or vice versa.
- Recheck polarity.

Checking function

1. Open the Line Converter box and switch on power supply by closing the power switch.
2. Open the Terminal box(es) and check if the green LED is lit at all busy connectors.

Checking relays

It is possible to release the ready-relay and the alarm-relays with the push button "TEST" at the backside of the MDA312-2 (see 1 at Fig.95)

After pressing the push button "TEST" at the backside of the MDA312... for min. 5 seconds the following action starts:

- 1.) all pre-alarms are activated for some seconds (i.e. the relays 1, 3, 5 are set)
- 2.) the pre-alarm relays are deactivated (i.e. the relays 1, 3, 5 are cleared) and the main-alarms are activated for approx. some seconds (i.e. the relays 2, 4, 6 are set).
- 3.) Main-alarms are deactivated (i.e. the relays 2, 4, 6 are cleared) and the system error-alarm is activated (i.e. the ready-relay is set) for approx. some seconds



Installation, fixing and commissioning

- 4.) system error-alarm is deactivated (i.e. the ready-relay is cleared)

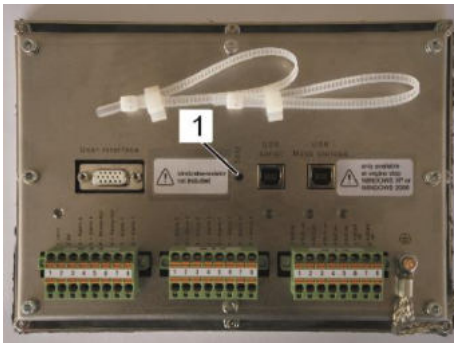

Fig. 95: Test button MDA312-2



NOTICE!

Malfunction through dirty sensors!

When a cable is displaced from a sensor it might get polluted by dirt and particles.

Therefore:

- Always place the foreseen cap onto the sensor cable and the sensor itself.

Preparing transport of an incomplete delivered engine

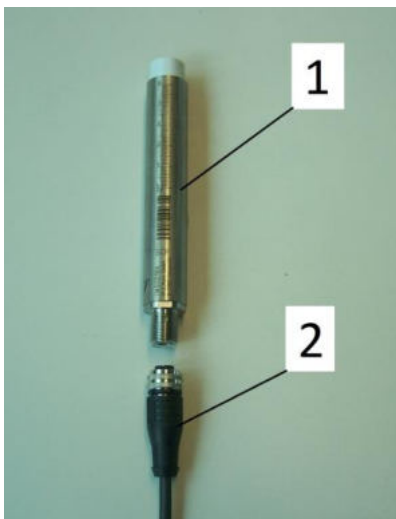

Fig. 96: Caps

When an engine is delivered in parts and not as a whole to the shipyard, the following works have to be carried out:

1. Open the Line Converter box and switch off the power supply.
2. Mark the sensor cable allowing a clear identification at reassembling which cable belongs to which sensor, left or right hand side.
3. Loosen the sensor cable from the sensor and place a cap on the sensor cable (Fig.96/2) as well as another one on the sensor (Fig.96/1) itself.



NOTE!

The caps are part of Dr. E. Horn's delivery.

4. Coil up the sensor cables and secure them in the engine bed plate.

**After transport of an incomplete delivered engine**

1. Remove the caps from sensor and sensor cable and connect them according to the marking.
2. Check the sensor brackets for damages. Replace them if necessary.
3. Open the Terminal box(es) and the Line Converter box.
4. When all sensors are connected switch on the power supply at the power switch.
5. Open the crankcase doors.
6. Check all LED in Terminal and Line Converter box for lighting.
7. If all LED are on close the crankcase door, the Terminal box(es) and the Line Converter box.

6.5 Commissioning

The crossheads are closing down nearer to the distance sensors at the moment of inertia with increasing speed. This has to be compensated by differed values that have to be stored in the system.

Please use only chapter 4 of document "User Interface Manual" DK0002208 to carry out the required procedure.

The systems alarms are active, after the first speed point is covered. After completion of all three speeds, the system will proceed into self learning mode for the next 500 engine running hours. During this period the fine calibration curve will be built.

**NOTE!**

The commissioning of the BDMS/BTMS is so far always necessary to start up the system. Although the system protects the engine already after the first speed point is covered, it is necessary to record 3 interpolation values to start the so called "learning phase".

The proof for the start of the 500 hours learning phase must be provided to the Dr. E. Horn GmbH & Co. KG!



Operation

7 Operation

7.1 Safety

Personal protective equipment

During operation no special protective equipment has to be worn.

Improper operation



WARNING!

Risk of injury due to improper operation!

Improper operation can result in severe personal injuries or material damage.

Therefore:

- Perform all the operating steps in accordance with the information in this operator’s manual.
- Ensure that all covers and safety devices are installed and in proper working condition before starting work.
- Never deactivate safety equipment during operation.
- Ensure tidiness and cleanliness in the working area. Loose components and tools lying around or on top of each other are sources of accidents.

7.2 Operating the Indication unit

If the system has been installed correctly all respective values subject to installed components can be monitored. All values are displayed on the Indication unit (Fig.97).

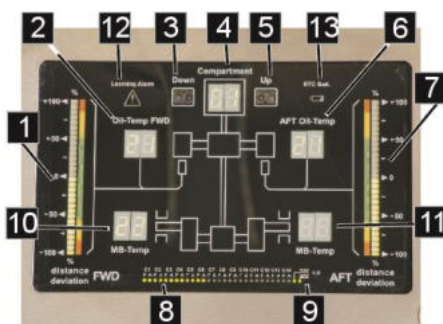

Fig. 97: Indication unit, full configuration

- 1 Distance deviation measured by FWD distance sensor
- 2 splash oil temperature at FWD distance sensor
- 3 Optical button “Down”
- 4 Compartment number
- 5 Optical button “Up”
- 6 splash oil temperature at AFT distance sensor
- 7 Distance deviation measured by AFT distance sensor
- 8 LED indicating the number of installed distance sensors
- 9 LED indicating installed H₂O sensor
- 10 Main bearing splash temperature
- 11 Main bearing splash temperature
- 12 Learning alarm
- 13 Real-Time-clock battery level low

1. Use the optical buttons “Up” (Fig. /2) and “Down” (Fig.97/4) to scroll through the different compartments.
2. Check all values with regard to what is expected.

The distance measured by the distance sensors is displayed with

**Distance deviation**

respect to the value that was built during learning mode just after system installation.

Oil temperature

The splash oil temperature is measured by the distance sensors as well. The respective temperature is presented as absolute value for each side of a compartment (Fig.97/1 and Fig.97/5).

**NOTE!**

The temperature of the splash oil near a distance sensor is measured with a tolerance of ± 2 °C.

Main bearing temperature (optional)

The temperature of the main bearings (Fig.97/7 and Fig.97/10) will be displayed when the engine has been started and the load increases.

**NOTE!**

When operating normally the temperature has to rise up close to or above the lube oil temperature.

Sensor status

The LED row Fig.97/8 indicate installed distance sensors for every compartment:

green – normal, no alarm

red – alarm limit exceeded

dark – sensor not installed or sensor not working or sensor connection not working.

The two LEDs Fig.97/9 show the installed water-in-oil sensor:

both LEDs green – normal, no alarm

PAV-LED red – Pre-alarm

both LEDs red – Main-alarm

both LEDs dark – sensor not installed or sensor not working or sensor connection not working.

Learning alarm

In learning mode the system first is sampling 1000 sensor measurement values at each speed point, corresponding to 1000 engine revolutions. An average – so called reference value – is calculated from the 1000 samples. The sampling of such reference values will, however, be continued for totally 500 hours of engine operation. In this period, the average at each speed point is recalculated every 50 hours based on available samples. If any further reference value at any speed point is changing by 0.2mm or more (compared to the first obtained valid value based on 1000 samples) the “Learning Alarm” is indicated.



Operation



CAUTION!

Risk of bearing damage

If “Learning Alarm” is indicated, possibly bearing wear is going on. The system cannot release “normal alarm” in every case, because it is adjusting in some way to the changing distance measurement values during learning mode

RTC Batt.

Battery lifetime is 10 years minimum. Red light indicates low level. Then the battery has to be changed to avoid loss of Real-Time-Clock, if system power will be switched off. A new battery has to be ordered from the supplier. For changing the MDA312 has to be opened at the backside. Setting of Real-Time-Clock is described in Chapter 7 of document “User Interface Manual” DK002208.



7.3 Testing a water-in-oil-sensor

Personal

- Sensor must only be tested by qualified personnel.

Personal protective equipment

Wear the following personal protective equipment when entering the compartment:

- Protective clothing
- Safety boots
- Safety gloves
- Hard hat
- Safety belt if it is necessary to bridge big heights



WARNING!

Danger of injury caused by oil under pressure!

In case of defective lines or machine parts oil may escape under pressure. This can cause severe injuries.

Therefore:

- Do not open pipelines under pressure.
- Depressurize pipelines before starting any work.
- Have defective parts repaired.



Fig. 98: Alarm indication on sensor cap

1. Press and hold the black button (Fig.98/1) on the sensor cap.



An alarm should be indicated on the sensor cap (Fig.98/2) and on the Indication unit (Fig.99/1) within the next ten seconds

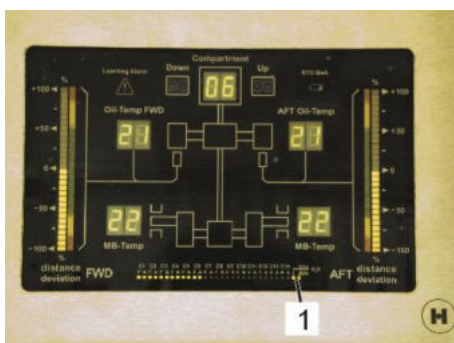

Fig. 99: Alarm indication on Indication unit



WARNING!

The WIO Sensor never should taken for test purpose in clear water !!!



Maintenance

8 Maintenance

8.1 Safety

Personnel

- The maintenance work described here cannot be executed by the operator unless otherwise indicated.
- Some maintenance tasks can only be executed by trained qualified personnel, or only by the manufacturer. In these cases this is separately indicated in the description of the specific maintenance tasks.
- All work on the electrical equipment should only be executed by a qualified electrician.

Personal protective equipment

Wear the following personal protective equipment at all maintenance work:

- Protective clothing
- Safety boots
- Hard hat
- Safety belt if it is necessary to bridge big heights



NOTE!

Other personal protective equipment that has to be worn at particular work will be mentioned in the warning notices in this chapter.

Electrical system



DANGER!

Electric power poses a fatal risk!

Contact with live parts may prove fatal. When switched on, electric components may be subject to uncontrolled movements and may cause very serious injury.

Therefore:

- Switch off the power supply before starting maintenance work, and make sure that it cannot be switched on accidentally.

**Engine****WARNING!****Danger to life caused by engine in progress!**

Starting the engine while working on or inside of it may cause very serious injury or even lead to death.

Therefore:

- Switch off the engine before performing any maintenance work and make sure that it cannot be switched on accidentally.

Securing against switching on**DANGER!****Danger to life caused by uncontrolled switching on again!**

There is a risk of the electric power supply or the engine being switched on again when performing maintenance work. This imposes danger to the life of persons in the danger zone.

Therefore:

- Before starting work, switch off all power supplies and secure against switching on again.

**WARNING!****Injury hazard posed by improperly executed maintenance work!**

Improper maintenance can cause severe injury or property damage.

Therefore:

- Prior to starting work ensure that there is sufficient assembly space.
- Ensure order and cleanliness at the assembly site! Loose parts and tools, parts and tools placed on top of each other are hazard sources.
- If components have been removed, ensure that they are properly mounted; re-install all mounting elements and comply with all screw tightening torque specifications.



Maintenance

Environmental Protection

Comply with the following environmental protection instructions when performing maintenance work:

- Wipe any emerging, used or excessive grease off all lubrication points that need to be manually supplied with lubricant, and dispose of in compliance with local regulations.
- Catch exchanged oil in suitable containers and dispose of in compliance with locally valid regulations.

8.2 Maintenance schedule

Maintenance tasks that are required for optimum and trouble-free operation are described in the sections below.

If increased wear is detected at regular inspections then the required maintenance intervals must be shortened by the customer to correspond with the actual signs of wear.

Contact the manufacturer for questions on maintenance work, see the service address on page 2.

Interval	Maintenance work	Proceeded by
At every opening of the crankcase door	Visually check the distance sensors and the cabling for damages. The LED must be lit.	Qualified personnel
	Visually check the main bearing sensors (if installed) and the cabling concerning being glued.	Qualified personnel
	Visually check the water-in-oil sensor (if installed). LED must be flashing.	Qualified personnel
Annually	Check all the cabling being laid for damages. Have them repaired or replaced immediately.	Professional electrician



8.3 Maintenance tasks

8.3.1 Changing distance sensors



CAUTION

Work should only be carried out by qualified personnel.
In case of displacement holder, check the sensor position.
If this is not the case, these must be adjusted as in User Manual DK002208, chapter 5).

- Maintenance work must only be carried out by qualified personnel.
- Also use chapter 5 and 6 of document “User Interface Manual” DK002208.
- Additionally required protective equipment:
 - Hard hat
 - Safety belt
 - Safety boots
 - Protective gloves



NOTE!

When a distance sensor is defective, the respective LED on the Indication unit will not be lit anymore. Distance sensors cannot be repaired, they have to be changed.

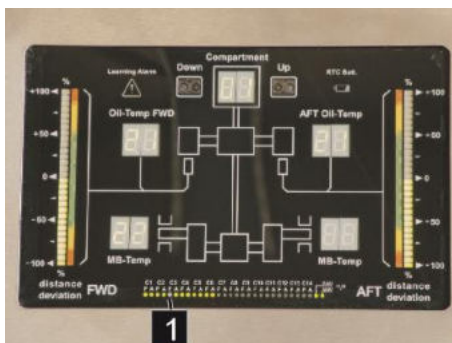

Fig.100: Indicating a defective sensor

The LED C3 (Fig.100/1) in the lower range of the Indication unit is off. The respective sensor is defective and has to be changed.

1. Order a new sensor from Dr. E. Horn.



NOTE!

We recommend taking our special tools for changing sensors (Fig./1) to have fewer complications with the exchange. The tools will be part of the hardware delivery.



Maintenance

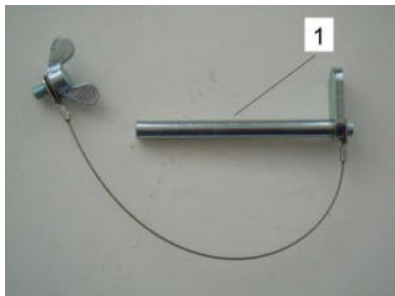

Fig.101: Special tool for all sensor brackets

■ Required tools:

- Special tools for changing defective sensors:

- 1 Special tool for changing a distance sensor for all sensor bracket



NOTE!

Before changing a sensor, the spare sensor has to provide with the cylinder-dependent ID. Please see the pages 9 – 12 in Handheld User Manual (DK002208) for changing the sensor ID.

Changing a sensor in a tube type sensor bracket

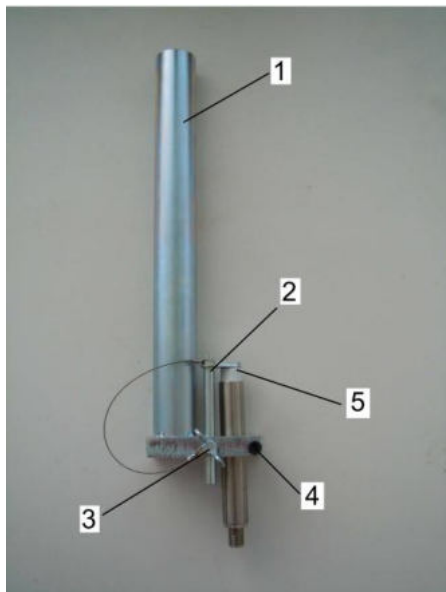

Fig.102: Tube type sensor bracket with tool

1. Stop engine and secure it against accidental restart (⇒ see Operating Instructions of the engine manufacturer).
2. Turn engine, so that the crosshead is away from the sensor which has to be change and working under the crosshead is possible (⇒ see Operating Instructions of the engine manufacturer).
3. Place the tool (Fig.102/2, 103/2) into the foreseen hole of the sensor bracket (Fig.102/1, 103/1).
4. Slide down the tool, until it rests on the sensor tip (Fig.102/5, 103/5).
5. Fix the tool by using the thumbscrew (Fig.102/3, 103/3).
6. Make sure that the tool is still in contact with the sensor (Fig.102/5, 103/5).
7. Disconnect the cable of the sensor.
8. Loosen the clamping bolt of the sensor (Fig.102/4, 103/4) and remove the sensor.
9. Insert a new sensor and make sure that it is in contact with the contact plate of the tool (Fig.102/5, 103/5).
10. Check the connector of the new sensor for correct placement.
11. Tighten the clamping bolt (Fig.102/4, 103/4) with a torque moment of 16 Nm.
12. Connect the sensor cable.
13. Remove the clamping bolt (Fig.102/3, 103/3) and remove the tool (Fig.102/2, 103/2).



NOTE!

Further adjustments are not necessary.

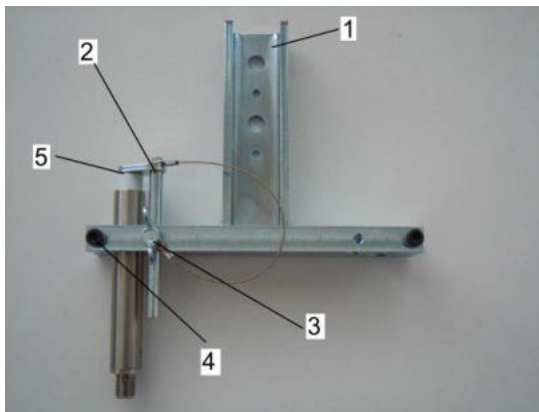

Fig. 103: Profile type sensor bracket with tool



Maintenance

8.3.2 Inspecting a main bearing after production test run

- Maintenance work must only be carried out by qualified personnel.
- Additionally required protective equipment:
 - Hard hat
 - Safety belt
 - Safety boots
 - Protective gloves

If a main bearing has to be inspected because of classification request it has to be opened. Follow this routine:

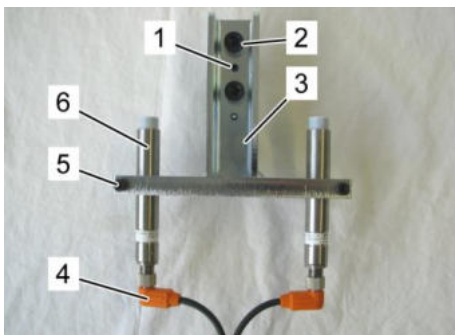

Fig.104: Sensor bracket with sensors

1. Disconnect the sensor cables (Fig.104/4) in the compartment where the inspection has to be made.
2. Leave sensors (Fig.104/6) in their position and do not open the clamping bolts (Fig.104/5).



NOTE!

When the clamping bolts get opened the sensors have to be arranged anew.

3. Remove the fastening bolts (Fig.104/2) of the sensor brackets.
4. Use on small brackets a large screwdriver and place it between the A-frame and the sensor bracket to separate the sensor brackets from the alignment pins (Fig.104/1). On larger brackets please use the threaded hole, insert a threaded bolt and press the bracket from the A-frame screwing the bolt down.
5. Remove the threaded bolt and place the sensor brackets with the sensors in a secure place.
6. Inspect the main bearing and reassemble it.
7. Place the sensor bracket (Fig.104/3) onto the alignment pins (Fig.104/1).
8. Insert the fastening bolts (Fig.104/2) with new Nord-Lock® discs and tighten them with the correct torque moment (⇒ see chapter 8.4).



NOTE!

According to the engine manufacturer MAN B&W never more than just one sensor per cylinder compartment should be removed.



8.4 Screw tightening torques

Component	Dimension	Value	Unit
Single sensor bracket, tube type	M10	70	Nm
	M12	120	Nm
Double sensor type, profile type	M8	35	Nm
	M10	50	Nm
Sensor clamping screw, all brackets	M6	16	Nm
Bolts for Terminal and Line Converter box	M8	16	Nm
Ground screw	M6	6	Nm

8.5 Measures after maintenance

Perform the following steps after completing maintenance and before switching on the machine:

1. Check all previously loosened screw connections for a tight fit.
2. Check whether all previously removed protective devices and covers are properly installed again.
3. Make sure that all tools, materials and other equipment used were removed again from the work area.
4. Clean up work area and remove any substances left over, such as fluids, processing material or the like.
5. Make sure that all safety features on the machine are fully functional.



Troubleshooting

9 Troubleshooting

The following chapter describes possible causes of faults and the steps required to eliminate them.

In the event of frequent faults, reduce the maintenance intervals to correspond to the actual working load.

In the event of faults that cannot be eliminated through the following instructions, please contact the manufacturer (service address on page 2).

9.1 Safety

Personnel

- All troubleshooting work on the electrical system must be performed by a qualified electrician.

Personal protective equipment

Wear the following personal protective equipment at all troubleshooting work:

- Protective clothing
- Safety boots
- Protective gloves
- Hard hat
- Safety belt if it is necessary to bridge big heights



NOTE!

Other personal protective equipment that has to be worn at particular work will be mentioned in the warning notices in this chapter.

Electrical System



DANGER! Electrocution hazard!

An electrocution hazard is posed by contact with live components. Switched on electrical components can execute uncontrolled movements and cause serious injuries.

Consequently:

- Prior to starting work, switch off the supply of electricity and ensure that it cannot be switched on again.

**Engine****WARNING!****Danger to life caused by engine in progress!**

Starting the engine while working on or inside of it may cause very serious injury or even lead to death.

Therefore:

- Switch off the engine before performing any maintenance work and make sure that it cannot be switched on accidentally.

Securing against switching on**DANGER!****Danger to life caused by uncontrolled switching on again!**

There is a risk of the electric power supply or the engine being switched on again when performing maintenance work. This imposes danger to the life of persons in the danger zone.

Therefore:

- Before starting work, switch off all power supplies and secure against switching on again.

**WARNING!****Unauthorized troubleshooting procedures can result in injury!**

Improper troubleshooting procedures can result in severe personal injury or material damage.

Therefore:

- Prior to beginning installation, ensure that there is sufficient space to work.
- Make sure that the assembly location is clean and well organized. Components that are loosely stacked or lying around can cause accidents.
- If components have been removed, ensure proper assembly, install all mounting elements and comply with screw tightening torques.



Troubleshooting

In case of faults:

The following general rules apply:

1. In the event of faults that pose immediate danger to man or machine, activate the emergency shutoff function immediately.
2. Determine cause of fault.
3. If elimination of the fault requires working in the danger zone, switch off unit and secure against being switched on again.
4. Immediately inform the person in charge at the equipment location of the fault.
5. Depending on the type of fault, eliminate the fault or have it eliminated by an authorized specialist.



NOTE!

The chapter "Troubleshooting" below provides information on who is authorised to eliminate the fault.



9.2 Troubleshooting chart

**NOTE!**

If the display unit MDA312... does not start, switch of the power supply (24V) for at least 1 minute. Then switch on the power supply (24V) again.

Trouble	Possible reason	Troubleshooting	Chapter
Indication unit is connected but not illuminated.	No electrical connection existing.	Check the status of the LED on the back.	9.3.1
		Check the fuse.	9.3.2
Indication unit is illuminated but bargraphs or temperature windows are flashing.	Bus cable is not connected.	Check the bus cable.	9.3.2
	Power switch in the Line Converter box is open.	Close power switch in the Line Converter box.	9.3.2
Distance sensor in the lower row of the display is missing.	Distance sensor is not connected.	Check connection of the sensor in Terminal box.	9.3.3
Main bearing temperature for one sensor is missing when scrolling through the compartments.	Main bearing temperature sensor is not connected.	Check connection of the sensor in Terminal box.	9.3.4
A water-in-oil sensor is not indicated in the display.	Water-in-oil sensor is not connected.	Check connection of the sensor in Terminal box.	9.3.5
No function of the Terminal box.	Terminal box is not connected.	Check if Terminal box is connected.	9.3.6



Troubleshooting

9.3 Troubleshooting

9.3.1 Checking the electrical connection of the Indication unit

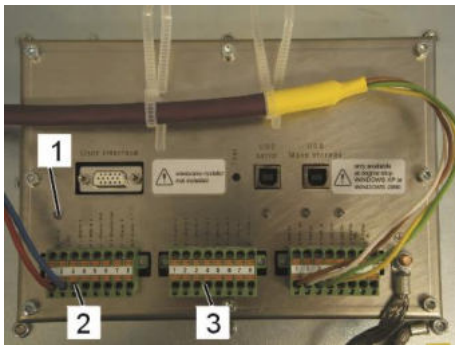

Fig.105: Indication unit

- Execution only by a qualified electrician.

1. Check if the LED (Fig.105/1) on the back of the Indication unit is lighting.
2. If the LED is off measure the voltage at the connectors X11 (Fig.105/2) and X12 (Fig.105/3).



NOTE!

A voltage of 24 V DC is required.

9.3.2 Checking the bus cables of the Indication unit and power supply

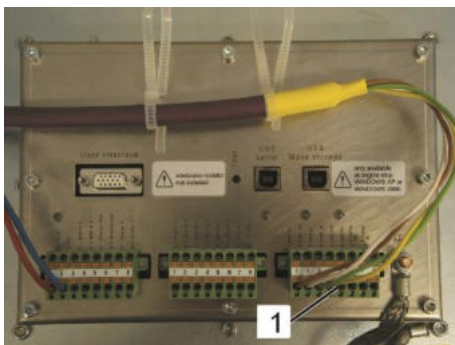

Fig. 106: Indication unit

- Execution only by a qualified electrician.

1. Check the connection of the bus cables (Fig.106/1) from X13/1 to X13/4 on the back of the Indication unit.

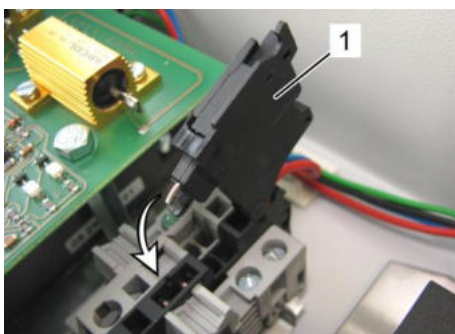

Fig.107: Power switch

2. If the bus cables are connected correctly open the Line Converter box and check whether the power switch is closed or not.
3. If not so close the power switch (Fig.107/1).
 - ↳ The LED at the connectors X1, X2 and X3 (Fig.108/1+2) must be on.

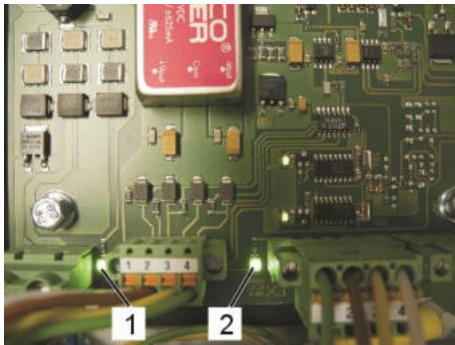

Fig.108: LED on

4. If the LED are off check the voltage at the power switch. It must be 24 V DC.

If there is no voltage measurable:

5. Check the power supply at the next connection in ship's supply system.

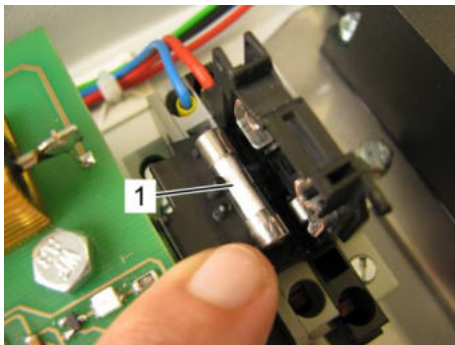

Fig.109: Fuse

If there is voltage measurable:

6. Remove the fuse (Fig.109/1) of the power switch handle and replace it by a new one.
 - AC supply voltage: 3.15 amperes delayed action, sand filled, size 5x20 mm
 - DC supply voltage: 6.3 amperes delayed action, sand filled, size 5x20 mm

↳ The LED must be on.

If there is still no power (green LED in Fig.108 off) and there is no voltage measurable at the main supply inlet:

7. Check the main supply the BDMS/BTMS system in the ship supply distribution system.

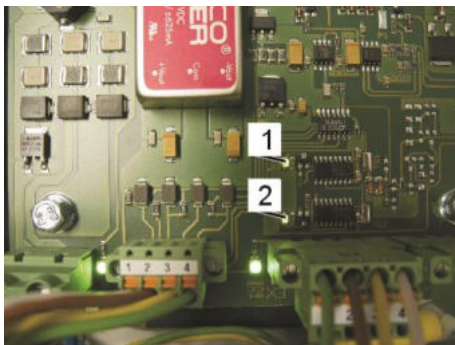

Fig.110: Bus LED

If there is power and the LED are on:

8. Check the bus connection at connector X2 inside the Line Converter box.
9. Remove the connector and replace it after 30 seconds.

↳ The two bus LED (Fig.110/1+2) must flicker indicating bus operation.
10. If the two bus LED are constant on check the bus connection from Line Converter box to Indication unit for damages.
11. Have defective cables replaced by new one of the same type.



Troubleshooting

9.3.3 Checking distance sensors

- Execution only by a qualified electrician.

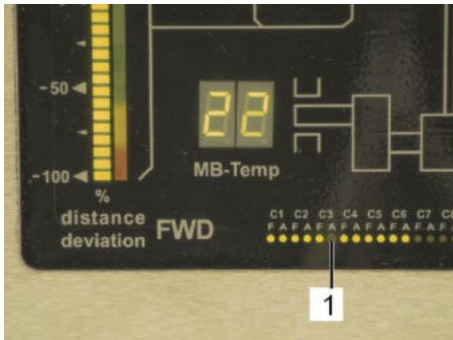

Fig. 111: Distance sensor missing

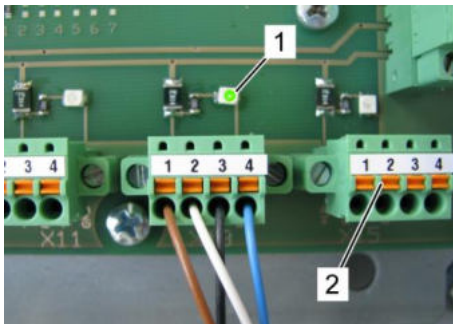

Fig. 112: Terminal box

1. Note: if the number of the distance sensor is not illustrated on the Indication unit (Fig. 111/1 means AFT sensor compartment 3)...

2. ...please open the Terminal box and check all connected terminals for the respective LED (Fig. 112/1) being on.
3. If a LED is off remove the respective connector (Fig. 112/2).
4. Replace the connector after 30 seconds.
 - ↪ The LED (Fig. 112/1) must be on.

If the LED just lights up shortly:

5. Open the respective crank house door and disconnect the connector from the sensor.
6. Check the connector for damages.
7. Replace the connector if defective.
8. Connect the connector to the sensor.
9. Check the LED for lighting.
 - ↪ If the LED is on the sensor works.
 - ↪ If the LED just lights up shortly the sensor is defective and has to be replaced (see chapter 8.3.1).



9.3.4 Checking main bearing temperature sensor

**NOTE!**

Except at the coupling or coupling counter side (depending on the mode of installation of the main bearing temperature sensors) the main bearing temperature will be indicated only one time per main bearing. In the coupling or coupling counter side compartment only the main bearing temperature of the first and second respectively the last and the penultimate bearing will be indicated.

- Execution only by a qualified electrician.

1. Note the number of the cylinder (Fig.113/1) and the position FWD (Fig.113/3) and AFT (Fig.113/2) respectively.

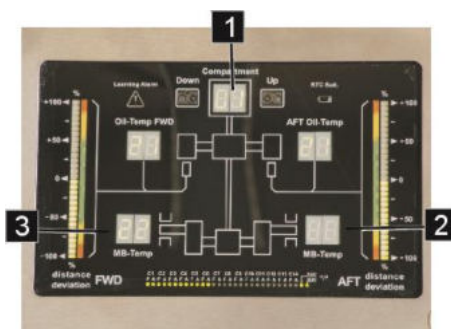

Fig.113: Indication unit

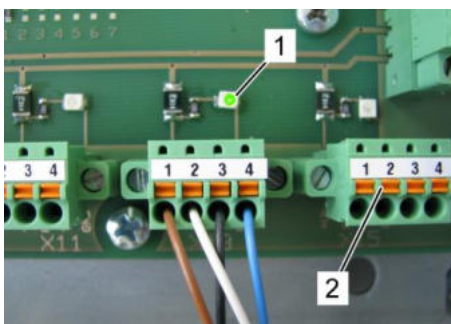

Fig. 114: Terminal box

2. Open the Terminal box and check all connected terminals for the respective LED (Fig.114/1) being on.
3. If an LED is off remove the respective connector (Fig.114/2).
4. Replace the connector after 30 seconds.
↳ The LED (Fig.114/1) must be on.

If the LED just shortly lights up the cabling or the main bearing temperature sensor itself is defective.

5. Have the cabling repaired or the sensor changed.



Troubleshooting

9.3.5 Checking water-in-oil sensor

- Execution only by a qualified electrician.

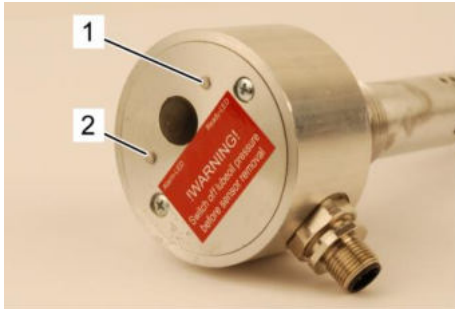

Fig. 115: Water-in-oil sensor

1. Check on the sensor itself if the LED is flashing.
2. If the LED are off remove the connector and replace it again.
 - ↳ LED must be flashing.

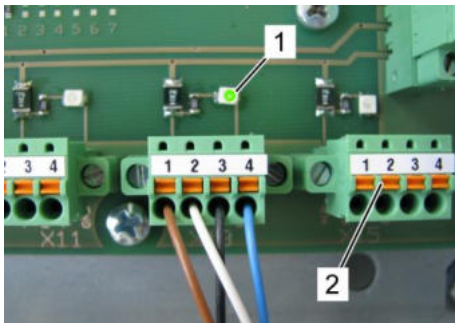

Fig. 116: Terminal box

If the LED are still off:

1. Open the Terminal box and check all connected terminals for the respective LED (Fig. 116/1) being on.
2. If a LED is off remove the respective connector (Fig. 116/2).
3. Replace the connector after 30 seconds.
 - ↳ The LED (Fig. 116/1) must be on.

If the LED just lights up shortly:

4. Check the cabling of the water-in-oil sensor completely.
5. If the cabling is not defective replace the sensor.

9.3.6 Checking function of the Terminal box

- Execution only by a qualified electrician.

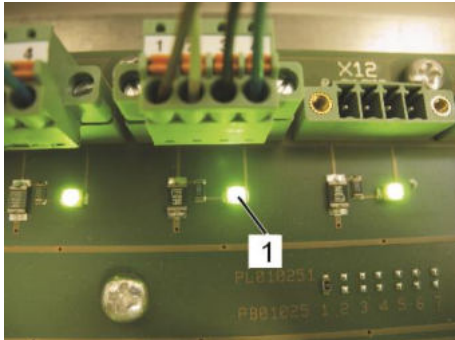

Fig.117: Terminal box

1. Open the Terminal box.
2. Check if the LED of all connected sensors are on (Fig.117/1).

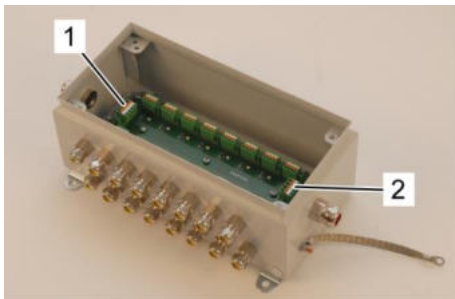

Fig.118: Bus connection in Terminal box

If no LED is on:

3. Check X17 (Fig.118/1) and X18 (Fig.118/2) respectively for correct cabling and insertion of the leads.
4. Measure the voltage at the connectors X17/1, X17/4 and X18/1, X18/4 respectively.
 - ↳ The voltage is 24 V DC.

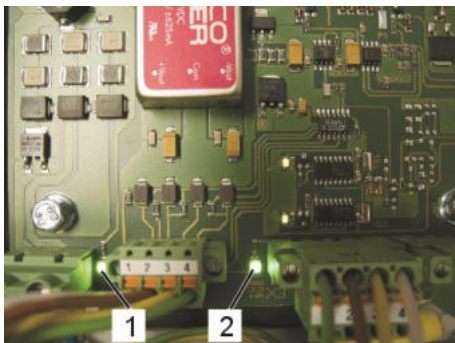

Fig.119: Line Converter box

If the voltage differs:

5. Open the Line Converter box.
6. Check if the LED is on (Fig.119/1+2).
7. Check the connections at X3 and X4.
8. Measure the voltage at the connectors X3/1, X3/4 and X4/1, X4/4 respectively.

If voltage is present and LED are on:

9. Check the cabling between Line Converter box and Terminal box for damages.
10. Have defective cables replaced by identical cable types.

9.4 Startup after eliminating fault

After remedying the fault, the following steps should be taken to restart the system:

1. Ensure that no one is in the danger zone.
2. Start up in accordance with the instructions in the “Installation” and “Operating” chapter.



10 Appendix

10.1 Installation schemata for the distance sensors

The following drawings show the installation schematics of distance sensors for engines on the example

- 14 cylinders (ANG00742-14)

Note: Cylinder counting is shown for MAN B&W engines only!

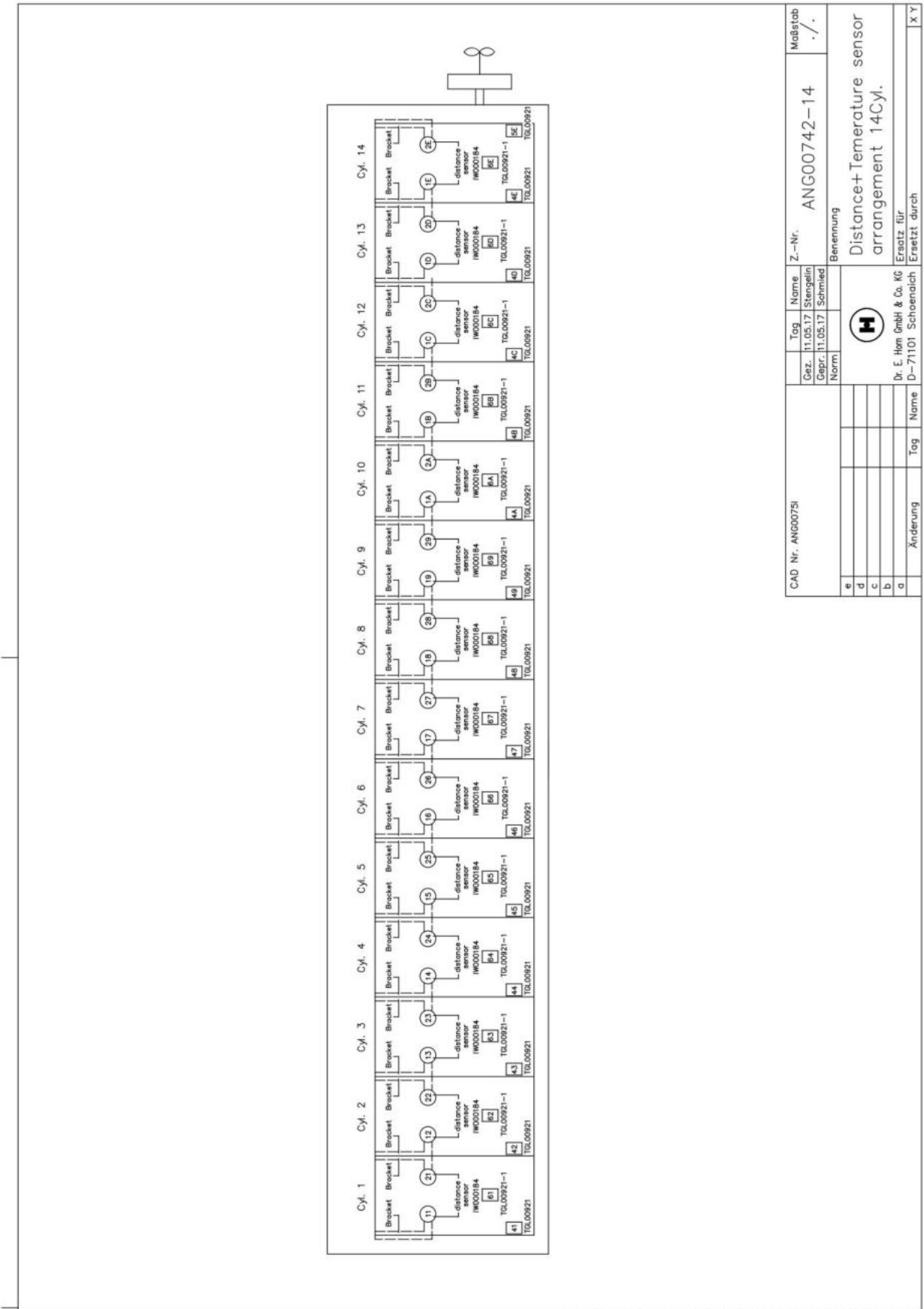

All rights reserved. Document may not be reproduced or disclosed to a third party or used for any other purpose without our written consent - Protection notice ISO 16016 is valid!



Appendix

10.2 Connection table Sensor-Terminal box

engine type:	Cyl. 1	Cyl. 2	Cyl. 3	Cyl. 4	Cyl. 5	Cyl. 6	Cyl. 7	Cyl. 8	Cyl. 9	Cyl. 10	Cyl. 11	Cyl. 12	Cyl. 13	Cyl. 14
Sensor-ID	IW000184	11, 21	12, 22	13, 23	14, 24									
	TGL00921	41	42	43	44/54									
	TGL00921-1	61	62	63	64									
Sensor-ID	IW000184	11, 21	12, 22	13, 23	14, 24	15, 25								
	TGL00921	41	42	43	44	45/55								
	TGL00921-1	61	62	63	64	65								
Sensor-ID	IW000184	11, 21	12, 22	13, 23	14, 24	15, 25	16, 26							
	TGL00921	41	42	43	44	45	46/56							
	TGL00921-1	61	62	63	64	65	66							
Sensor-ID	IW000184	11, 21	12, 22	13, 23	14, 24	15, 25	16, 26	17, 27						
	TGL00921	41	42	43	44	45	46	47/57						
	TGL00921-1	61	62	63	64	65	66	67						
Sensor-ID	IW000184	11, 21	12, 22	13, 23	14, 24	15, 25	16, 26	17, 27	18, 28					
	TGL00921	41	42	43	44	45	46	47	48/58					
	TGL00921-1	61	62	63	64	65	66	67	68					
Sensor-ID	IW000184	11, 21	12, 22	13, 23	14, 24	15, 25	16, 26	17, 27	18, 28	19, 29				
	TGL00921	41	42	43	44	45	46	47	48	49/59				
	TGL00921-1	61	62	63	64	65	66	67	68	69				
Sensor-ID	IW000184	11, 21	12, 22	13, 23	14, 24	15, 25	16, 26	17, 27	18, 28	19, 29	1A, 2A			
	TGL00921	41	42	43	44	45	46	47	48	49	4A/5A			
	TGL00921-1	61	62	63	64	65	66	67	68	69	6A			
Sensor-ID	IW000184	11, 21	12, 22	13, 23	14, 24	15, 25	16, 26	17, 27	18, 28	19, 29	1A, 2A	1B, 2B		
	TGL00921	41	42	43	44	45	46	47	48	49	4A/5A	4B/5B	1C, 2C	
	TGL00921-1	61	62	63	64	65	66	67	68	69	6A	6B	6C	
Sensor-ID	IW000184	11, 21	12, 22	13, 23	14, 24	15, 25	16, 26	17, 27	18, 28	19, 29	1A, 2A	1B, 2B	1C, 2C	
	TGL00921	41	42	43	44	45	46	47	48	49	4A/5A	4B/5B	4C/5C	
	TGL00921-1	61	62	63	64	65	66	67	68	69	6A	6B	6C	
Sensor-ID	IW000184	11, 21	12, 22	13, 23	14, 24	15, 25	16, 26	17, 27	18, 28	19, 29	1A, 2A	1B, 2B	1C, 2C	1E, 2E
	TGL00921	41	42	43	44	45	46	47	48	49	4A/5A	4B/5B	4C/5C	4E/5E
	TGL00921-1	61	62	63	64	65	66	67	68	69	6A	6B	6C	6E



10.3 System installation schemata

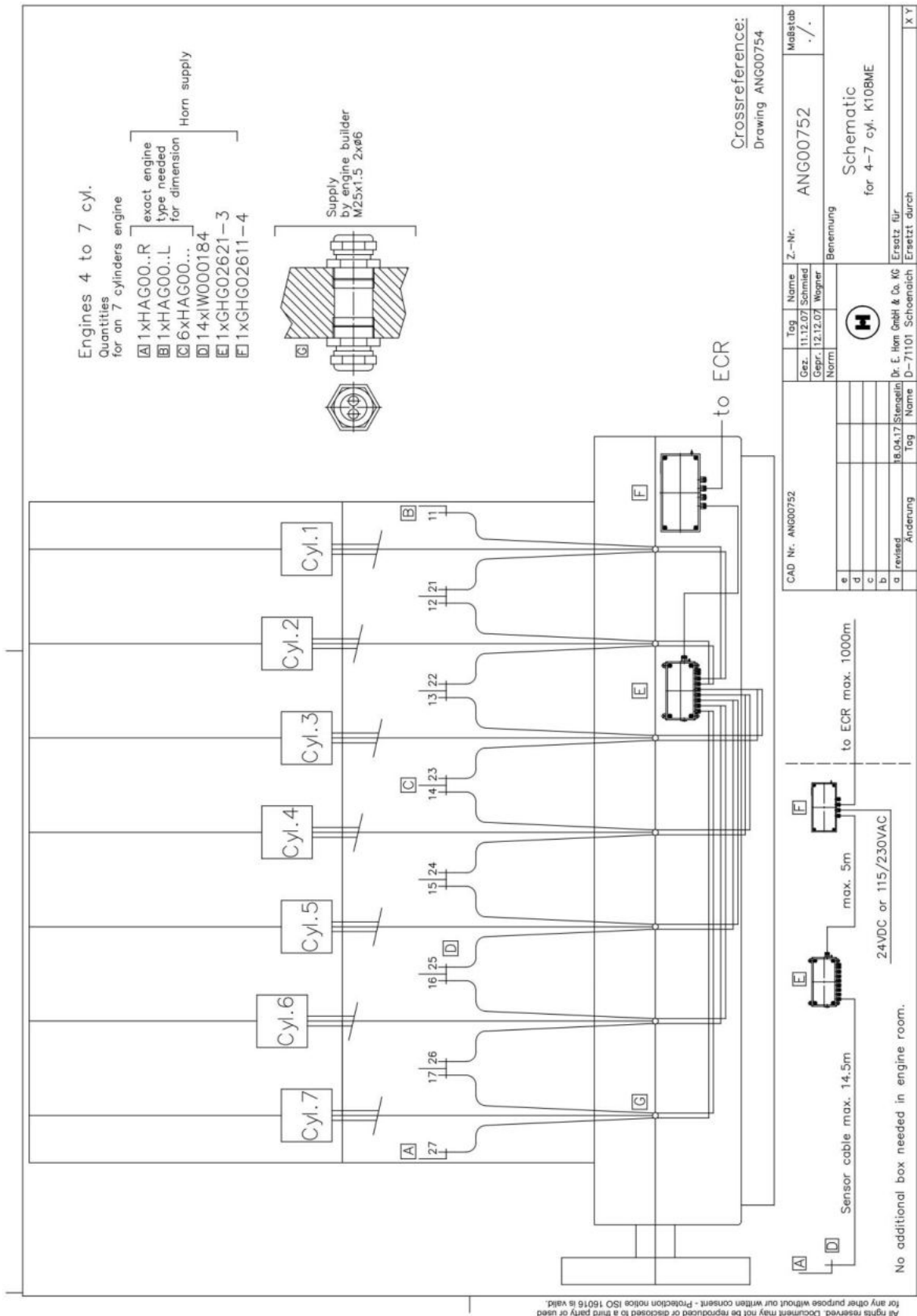

All rights reserved. Document may not be reproduced or disclosed to a third party or used for any other purpose without our written consent - Protection notice ISO 15076 is valid.



11 Index

A	
Accident.....	19
Adhesive.....	17
Appendix.....	115
Assemblies.....	30
B	
Brackets.....	34
Brief description.....	29
C	
Cables.....	68
Checks.....	91
Commissioning.....	49, 93
Connection.....	41
Contact.....	10
Copyright.....	9
Customer Service.....	10
D	
Danger zones.....	19, 43
Distance sensor.....	30
Checking.....	111
E	
Ear defenders.....	15
Electric Current.....	15
Emissions.....	27
Environmental protection.....	20
F	
Fire.....	19
First Aid.....	19
H	
Hard hat.....	14
I	
Indication unit.....	39
Checking electrical connection.....	109
Connecting.....	85
Installation.....	84
Installation.....	49, 53
Preface.....	53
Schemata.....	115
schemata system.....	118
L	
Liability.....	9, 13
Lifting eyes.....	46
Line Converter box.....	38
Connecting.....	80
Lubricants.....	20
M	
Main bearing	
Inspection.....	103
Main bearing temperature sensor.....	32
Checking.....	112
Maintenance.....	98
Maintenance schedule.....	100
Maintenance tasks.....	101
Mounting advisory for TGL00921-... temperature sensors.....	33
N	
Noise.....	18
O	
Oil pressure.....	16
Operating elements.....	44
Operating materials.....	17
Operation.....	94
Overview.....	28
Owner.....	11
P	
Packing.....	45, 47
Personal protective equipment.....	14
Personnel.....	12
commissioning.....	49, 105
installation.....	49, 105
maintenance.....	98



Index

Pneumatics	16	Tube type.....	34
Preface.....	53	Sensors	30
Professional electrician.....	12	Testing.....	97
Protective clothing	14	Spare parts.....	10
Protective equipment		Storage.....	45, 48
Installation and commissioning	49	Surfaces	
Maintenance.....	98	hot.....	18
Operation.....	94	Symbols	
Troubleshooting	105	in this manual	8
Protective gloves	14	T	
Purpose.....	13	Technical data.....	21
Q		Terminal box	37
Qualified personnel.....	12	Checking.....	114
R		Connecting	76
Risk of fire	17	Installation	76
S		Transport.....	45, 46
Safety		Crane.....	46, 47
general	11	Forklift truck.....	47
Safety belt	14	Inspection	46
Safety boots	14	Troubleshooting	105, 109
Screw tightening torques	104	Chart.....	108
Sensor		U	
Changing	101	Use.....	13
Connecting	78	V	
Counting	117	Vibrations	16
Distance	30	W	
Main bearing temperature	32	Warranty.....	10
Water-in-oil.....	28, 31	Water-in-oil sensor.....	28, 31
Sensor brackets.....	34	Checking.....	113
Installation	55	Work zones	43
Profile type	35		